

Royal Orchard Community Liaison Committee

December 2023



Agenda

Welcome

- Land Acknowledgement
- Safety Moment
- Housekeeping and Introductions

Presentations

- CLC Overview & Terms of Reference
- Project Overview
- Recent Milestones & Progress

Feedback and Discussions

- Next Meeting Topics
- Q & A



Land Acknowledgement

Let us take a moment to acknowledge we are on lands that have been, and continue to be, home to many Indigenous Peoples including the Anishnabeg, the Haudenosaunee and the Huron-Wendat peoples.

We are all Treaty people. Many of us have come here as settlers, as immigrants or involuntarily as part of the trans-Atlantic slave trade, in this generation, or generations past.

We acknowledge the historic and continued impacts of colonization and the need to work towards meaningful reconciliation with the original caretakers of this land.

We acknowledge that Metrolinx operates on territories and lands covered by many treaties that affirm and value the rights of Indigenous communities, Nations and Peoples.

We understand the importance of working towards reconciliation with the original caretakers of this land. At Metrolinx, we will conduct business in a manner that is built on a foundation of trust, respect and collaboration.

Safety Moment

With weather conditions worsening remember to:

- Check weather and road conditions often.
- Keep a safe distance behind snow plows.
- If you don't already have them, get winter tires.
- Slow down and give yourself extra travel time.
- Clear snow and ice from your vehicle.

THINK Safe

DRIVE Safe

HOME safe



Community Liaison Committee

Community Liaison Committees (CLC) provide a forum for open, two-way communication and sharing of information between the community and Metrolinx. It serves as for forum to learn about community perspectives, concerns, and questions, and to foster a collaborative approach during the course of the project.

- The CLC will meet regularly (cadence to be determined by consensus).
- Metrolinx will propose meeting agenda with input from committee members.
- Meetings will be approximately 60-90 minutes.
- Metrolinx will chair the CLC.
- Action items to be logged in meeting minutes for follow-up.



Community representatives

- Elected officials
- Residents and associations
- Markham Board of Trade
- Business owners



City of Markham







- Planning and Urban Design



Project team members

- Metrolinx Community Engagement
- Metrolinx project team and subject matter experts as appropriate

Project Overview

-  ~8km Route
-  5 new stations
-  94,000 daily riders
-  Up to 22 minutes saved on a trip from York Region to downtown Toronto
-  4,800 tonnes in yearly greenhouse gas emission reductions
-  26,000 more people within 10-minutes walk to transit
-  7,700 fewer km traveled by cars during morning rush hour

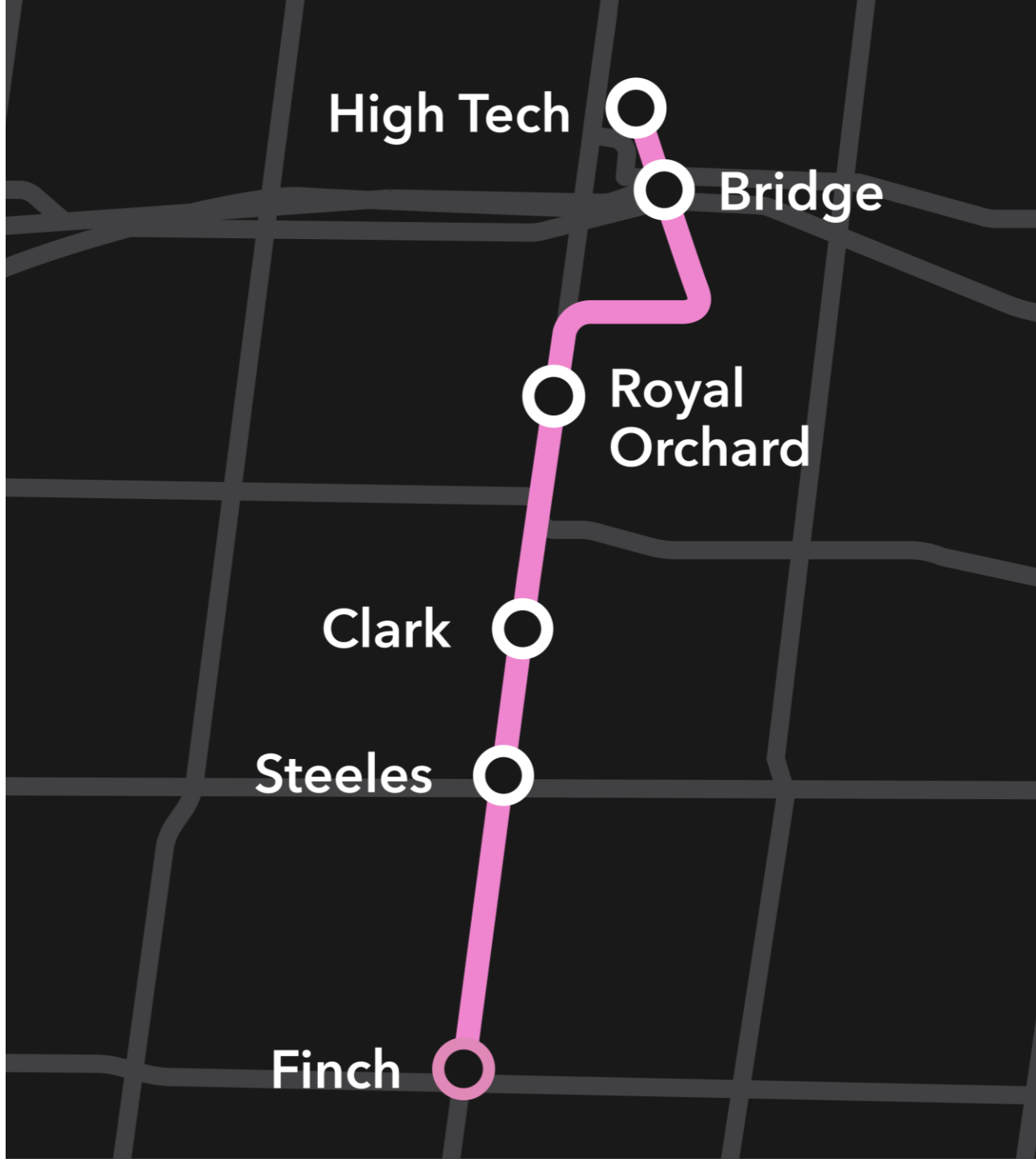

A Launchpad to Explore the Region

- A new **transit hub** at Bridge Station will open up new travel possibilities in York Region and beyond.
- Brings **convenient transit access** to the heart of the Richmond Hill Centre and Langstaff Gateway development areas
- This will lead to **less traffic congestion** as these communities grow
- Offers fast and convenient transfers to as many as **seven existing and future regional transit lines**

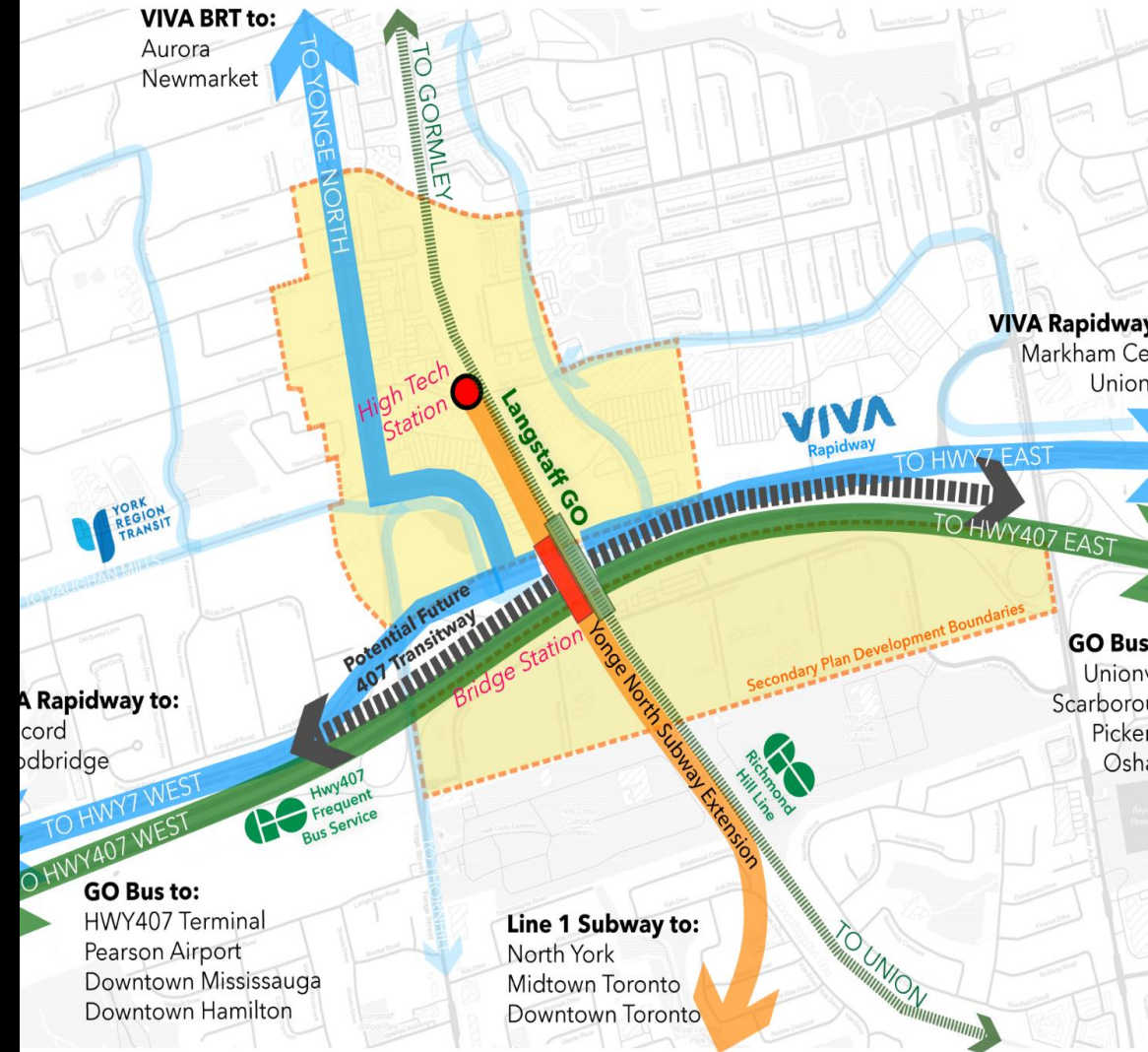

Timeline to Date

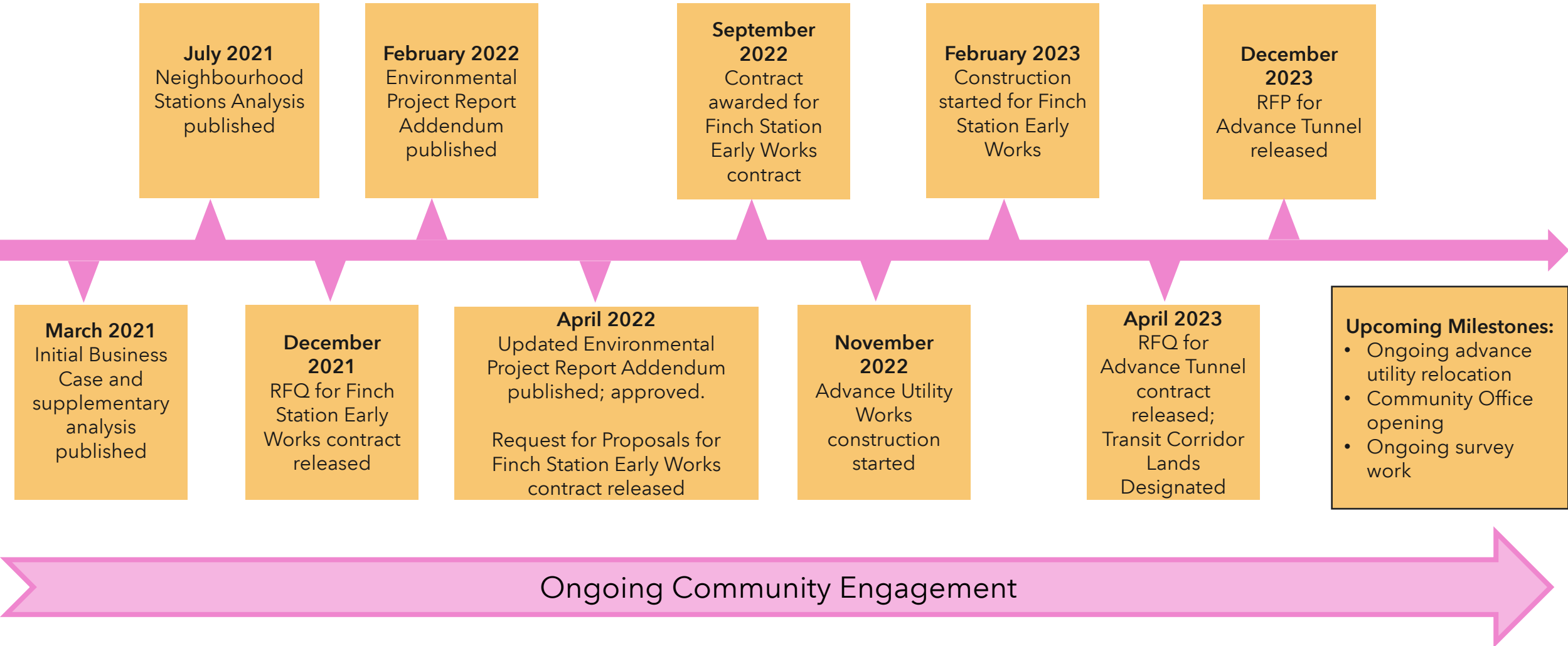

Recent Milestones & Progress

Finch Early Works - Near Completion

- Initial project to prepare existing Finch station for future subway tunneling
- Restoration of temporary traffic signals, pedestrian walkway and Yonge-Hendon intersection underway
- Success using the noise monitoring system- team alerted of any instances of exceedance allowing prompt inspection and resolution of the issue
 - **Zero** noise complaints received during duration of the project



Advanced Utility Works Relocations

- Utility relocations along Yonge Street are ongoing to prepare for future construction.
- Two week minimum advance notice provided
- Currently two active utility works underway in the City of Toronto and York Region.
 - Yonge-Clark; Yonge-Grandview





- The advance tunnelling RFP has been issued to three shortlisted bidders asking them to submit formal proposals on how they would design, build and finance tunnelling work for the project.
 - CrossTransit Group
 - North End Connectors
 - Toronto-York Tunnel Connectors

Tunnelling work will begin after we finalize a detailed schedule with our future tunnelling team. We expect to name a successful bidder in late 2024

Scope

- Twin bore tunnels, including two tunnel boring machines
- Headwalls (stations, emergency exit buildings)
- Launch shaft construction (including ground improvement)
- Extraction shaft construction (including support of excavation)
- Site restoration

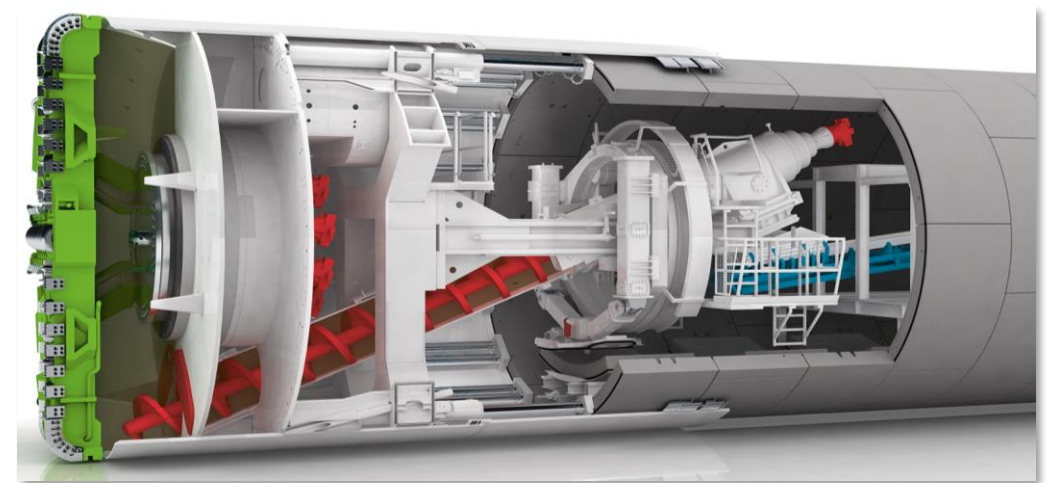

PRELIMINARY SHORT-TERM PROJECT STEPS

- Advance Tunnel Contract RFP was released on December 1st, contract is to be awarded by the **end of 2024**.
- Project timelines related to tunnelling will be finalized with the Project Company once they are on board.
- Updates on milestones and next steps in the project will be communicated with stakeholders as they are finalized.
- **Known upcoming work:** ongoing environmental site assessments (e.g. groundwater sampling) and archeological assessments
 - Notices provided at least two weeks in advance, where possible

We're Here For You!

Our goal is to make sure local neighbourhoods and businesses stay accessible and informed throughout this important project.

Our approach is all about keeping you informed and involved. In 2023, this included:

54 Pop-up events

2,770 in-person interactions

8,000 doors knocked via canvassing

1,700 construction notices dropped

Visit our community office (opening soon) and try our sound simulation experiences.

At the kiosk experiences and in our custom Listening Room, you will have the chance to hear what's coming to your community.



We would love to hear from you on other ways to engage.





Pillar One:
Employment
Opportunities

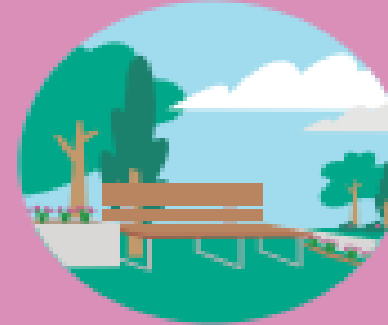

Pillar Three:
Public Realm
Improvements

Next Meeting: Community Benefits & Supports

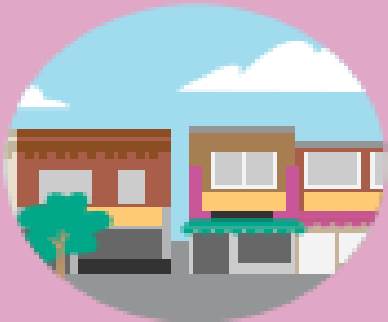

Pillar Two:
Local Business
Supports



Pillar Four:
Community
Improvement
Supports

Potential Topics for Future CLCs

Tunnelling 101

Emergency
Exit
Buildings

Requests?

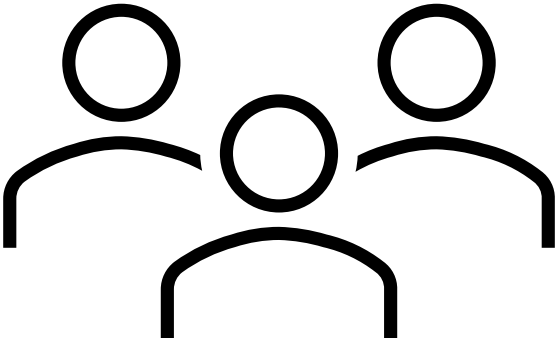

Next Steps

Next Meeting:

- Preference for February or March?
- In person, virtual, or hybrid?
- Share materials and minutes with CLC members and post online
- Confirm agenda topics for future meetings based on presenter availability

