

VINYL STREAM LABELS

STAINLESS STEEL QUARTER

FRONT PANEL SHOWN IN OPEN POSITION FOR REMOVAL OF LINERS

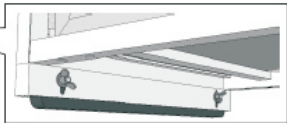

Adj Rubber Footing (.75" x 3.00" x 17.00")

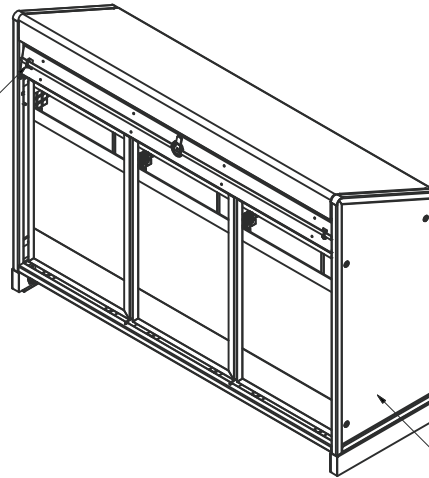

ISO. VIEW FRONT

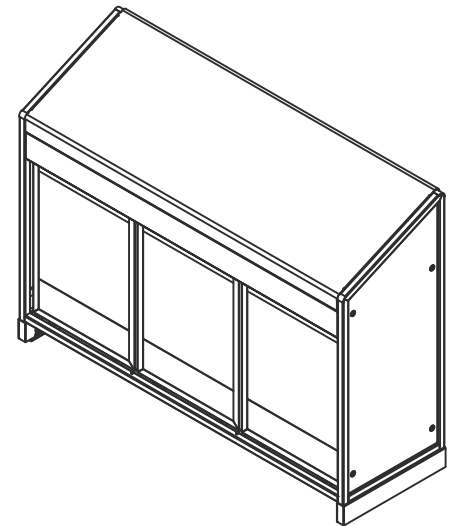

ISO. VIEW REAR

FROSTED POLYCARB SIDE PANEL

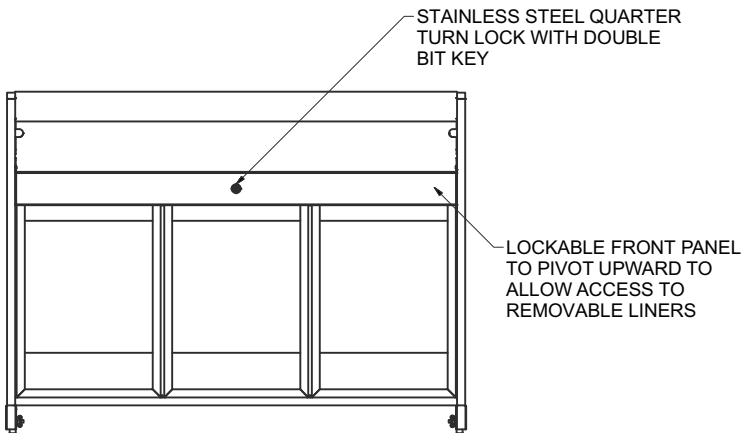

FRONT VIEW

CA-296-S

STAINLESS STEEL QUARTER TURN LOCK WITH DOUBLE BIT KEY

LOCKABLE FRONT PANEL TO PIVOT UPWARD TO ALLOW ACCESS TO REMOVABLE LINERS

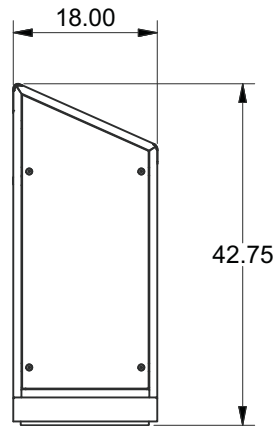

SIDE VIEW

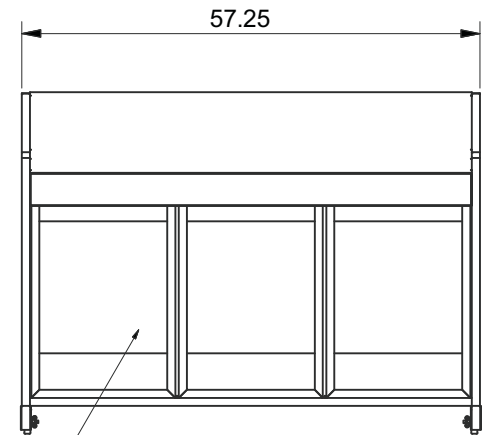

REAR VIEW

CLEAR POLYCARB INSERTS TYP

PROPRIETARY NOTE: THIS DRAWING AND THE INFORMATION CONTAINED HEREIN IS PROPRIETARY TO ROYAL-LASER AND SHALL NOT BE REPRODUCED, COPIED, OR DISCLOSED IN WHOLE OR IN PART FOR USE FOR MANUFACTURE OR FOR ANY PURPOSE WITHOUT ITS WRITTEN PERMISSION.

COMPANY:

envyroz
enhancing your environment

25 Claireville Drive
Toronto, Ont, M9W 5Z7
www.envyrozzone.com

TITLE
CA-296-S

TOLERANCE TABLE
X = 0.06 (1.50 mm)
XX = 0.03 (0.75 mm)
XXX = 0.01 (0.25 mm)
ANGULAR= 1

DRAWN Paul.Machado 4/29/2019

DWG NO

REV

CHECKED

CA-296-S

V2

APPROVED

Customer:

REV

MFG

METROLINX

Mat'l:

SIZE

C

SHEET 1 OF 1

SCALE NTS

PROJECTION: THIRD ANGLE