

Electrical Identification and Nomenclature Specification

Specification 26 05 53

Revision 01
Date: March 2023

Electrical Identification and Nomenclature Specification

Specification 26 05 23

Publication Date: December 2017

Revision Date: March 2023

COPYRIGHT © 2017

Metrolinx,

an Agency of the Government of Ontario

The contents of this publication may be used solely as required for and during a project assignment from Metrolinx or for and during preparing a response to a Metrolinx procurement request. Otherwise, this publication or any part thereof shall not be reproduced, re-distributed, stored in an electronic database or transmitted in any form by any means, electronic, photocopying or otherwise, without written permission of the copyright holder. In no event shall this publication or any part thereof be sold or used for commercial purposes.

The information contained herein or otherwise provided or made available ancillary hereto is provided "as is" without warranty or guarantee of any kind as to accuracy, completeness, fitness for use, purpose, non-infringement of third-party rights or any other warranty, express or implied. Metrolinx is not responsible and has no liability for any damages, losses, expenses or claims arising or purporting to arise from use of or reliance on the information contained herein.

Amendment Record Sheet

Amendment in Clause No.	Date of Amendment	Description of Changes
Various	March 2023	<ul style="list-style-type: none">- Introduced cable and raceway nomenclature- Created labelling conventions with examples for different types of electrical equipment- Added abbreviations for a site/destination table as part of the labelling convention
	March 2023	Reformatted the document to match the current specification format
	March 2023	Renamed and renumbered the document to match the current specification format

LIST OF CONTENT

1. GENERAL.....	4
1.1. SCOPE OF WORK	4
1.2. GENERAL REQUIREMENTS	4
1.3. REFERENCES	5
2. EXECUTION	7
2.1. PRINCIPLES	7
3. IDENTIFICATION.....	8
3.1. LABELLING	8
3.2. SITE LOCATION AND SPACES	9
3.3. EQUIPMENT AND PANELS	13
3.4. RACEWAY, PIPE, TRAY, THROUGH AND PATHWAY	14
3.5. TRACTION POWER AND HIGH VOLTAGE RACEWAY.....	16
3.6. CABLE TRAY.....	16
3.7. CABLE TROUGH.....	16
3.8. CONDUITS USED FOR BACKBONE CABLING	17
3.9. ELECTRICAL EQUIPMENT	18
3.10. PULL AND JUNCTION BOXES.....	22
3.11. RECEPTACLES, FIRE ALARM AND DUCT RESISTORS.....	23
3.12. UNDERGROUND WARNING TAPE	23
3.13. MANHOLE AND HANDHOLE MARKERS	24
3.14. NAMEPLATES	24
3.15. NAMEPLATES FOR FIELD DEVICES	24
3.16. COVER PLATE.....	25
3.17. NAMEPLATES FOR ROOM SENSORS.....	25
3.18. WARNING SIGNS	25
3.19. SYSTEM COLOURS	25
3.20. PNEUMATIC TUBING.....	26
3.21. COPPER WIRE, FIBRE STRAND, AND CABLE IDENTIFICATION	26
3.22. PATCH COPPER CABLE COLOUR STANDARDS	27
3.23. PATCH FIBRE CABLE COLOUR STANDARDS.....	27
3.24. POWER AND COMMUNICATIONS CABLES.....	28
4. BACKBONE.....	29
4.1. INTRA-BUILDING BACKBONE CABLING.....	29
4.2. INTER-BUILDING BACKBONE CABLING	30
4.3. INTER-SITE BACKBONE CABLING	31
4.4. INTER-SITE BACKBONE CABLING FOR ELECTRIFICATION, IT AND SIGNALS	32
5. DIFFERENT SYSTEMS IDENTIFICATION REQUIREMENTS.....	34
5.1. METROLINX SUBGROUPS.....	34
5.2. SYSTEM NAMEPLATES	35

6. SUBMITTALS	35
7. TYPICAL NAME PLATE SIZES	35
8. STANDARD ABBREVIATIONS	36
9. EXECUTION	60
9.1. SUBMITTALS	60
9.2. APPROVALS	60
9.3. PRODUCTS.....	60
9.4. COLOURS.....	61
9.5. LABELS AND NAMEPLATES.....	62
9.6. INSTALLATION PROCEDURES	64
10. SYSTEM SPECIAL REQUIREMENTS.....	65
10.1. SIGNALLING	65
11. EXAMPLES	70
12. SIGNALLING ELECTRICAL EQUIPMENT.....	73
13. ELECTRIFICATION REQUIREMENTS.....	73
14. QUALITY ASSURANCE	73
TABLES	
TABLE 1: SYMBOLS	8
TABLE 2: SITE/ DESTINATION TABLE	9
TABLE 3: FUNCTION TABLE	10
TABLE 4: EQUIPMENT IDENTIFICATION TABLE	19
TABLE 5: VOLTAGE COLOUR IDENTIFICATION FOR LINE VOLTAGE EQUIPMENT	21
TABLE 6: WALL JACK COLOUR STANDARDS.....	25
TABLE 7: SYSTEM COLOUR IDENTIFICATION FOR LOW VOLTAGE SYSTEMS EQUIPMENT	26
TABLE 8: BACKBONE CABLES	26
TABLE 9: PATCH COPPER CABLE COLOUR STANDARDS	27
TABLE 10: SAMPLE CABLE REPORT	33
TABLE 11: WIRE AND BOX IDENTIFICATION: VOLTAGE LEVEL COLOUR FOR LINE VOLTAGE EQUIPMENT.....	33
TABLE 12: NAME PLATE SIZES	35
TABLE 13: ABBREVIATIONS.....	36
TABLE 14: CONDUIT FUNCTION IDENTIFIERS	66
TABLE 15: EXAMPLE OF SIGNALLING CIRCUITS IDENTIFICATION.....	68
TABLE 16: EXAMPLE OF VITAL RELAY WIRING IDENTIFICATION.....	68

TABLE 17: EXAMPLE OF CABLE LABELLING68
TABLE 18: ELECTRICAL EQUIPMENT PRODUCT IDENTIFIERS69

FIGURES

FIGURE 1: DEVICE AND WIRING IDENTIFICATION70

1. GENERAL

1.1. SCOPE OF WORK

- 1.1.1. The purpose of this document is to provide a framework for identification of all the identified components in a consistent, understandable, scalable, and repeatable method throughout Metrolinx for all its electrical and communications systems.
- 1.1.2. This standard provides a unique naming, logging and identification system for the following:
- a) Standard labelling nomenclature for site;
 - b) Wire and cable markers;
 - c) Conduit and pipe markers and identification tags and labels;
 - d) Tray markers and identification tags and labels;
 - e) Equipment such as but not limited to pumps, motors, fans, panels, mcc, switchgear, panels, raceway etc., markers and identification tags and labels;
 - f) Pull and junction box identification;
 - g) Receptacle and plate identification;
 - h) Fire alarm identification;
 - i) End of line resistances markers and identification tags and labels;
 - j) Communication and electrical cabinet identification;
 - k) Manhole and handhole (handwells) markers and identification tags and labels;
 - l) Underground warning tapes;
 - m) Underground locate surface temporary colour identification ground marking;
 - n) Systems markers and identification and labels; and
 - o) Fire stop.

1.2. GENERAL REQUIREMENTS

- 1.2.1. The requirements set out in this standard detail the nomenclature requirements for identifying and labelling all electrical installation drawings and its elements. Where identification or labelling is required, it shall meet the following general requirements:
- a) Identifications shall be in English or as directed by Metrolinx;

- b) All electrical elements such as equipment, piping, raceways, conductors, instruments, control, and electrical devices shall be identified and labeled;
- c) A standard nomenclature identification method that includes all the necessary information for keeping the key business operating with minimum system interruptions shall be provided. Alternative methods of labelling may be submitted for approval;
- d) The names, abbreviations, colours, and other designations used for identification shall be coordinated with the corresponding designations indicated in the Contract Documents or required by codes and standards. Consistent designations shall be used throughout the project. All designations shall be subject to Metrolinx approval; and
- e) Identification Devices:
 - 1) A single type of identification product shall be used for each application category; and
 - 2) Use colours and abbreviations pre-scribed by this Specification.

1.3. REFERENCES

1.3.1. This standard refers to the use of, but not limited to the following specifications, standards, and publications. The latest editions shall be used:

- a) GO Design Requirements Manual (DRM);
- b) Metrolinx Standard Specifications and Drawings;
- c) American Society of Mechanical Engineers (ASME):
 - 1) ASME A13.1 - Scheme for the Identification of Piping Systems
- d) 29 CFR 1910.144 Safety color code for marking physical hazards;
- e) International Electrotechnical Commission (IEC):
 - 1) IEC 62507 Identification systems enabling unambiguous information interchange - Requirements;
 - 2) IEC 60027 Letter symbols to be used in electrical technology;
 - 3) IEC 60446 Wiring colours; and
 - 4) IEC 60617 Graphical symbols for diagrams.
- f) National Electrical Code (NEC):
 - 1) NEC 630.31 Photovoltaic Labelling; and

- 2) NEC 690 Photovoltaic Labelling.
- g) American National Standards Institute (ANSI)/Telecommunications Industry Association (TIA):
 - 1) ANSI/TIA 606B and ANSI /TIA 606 A - Administration Standard for Telecommunications Infrastructure. Latest version;
 - 2) ANSI/TIA-1005 Telecommunications Infrastructure for Industrial Premises; and
 - 3) ANSI Z535.4 for safety signs and labels.
 - h) American Railway Engineering and Maintenance-of-Way Association (AREMA);
 - i) European Standard:
 - 1) EN 50122-1: Railway Applications, Fixed Installations - Protective Provisions Relating to Electrical Safety and Grounding; and
 - 2) EN 50122-3 Railway Applications, Fixed Installations - Protective Provisions Relating to Electrical Safety and Grounding Mutual interaction of AC and DC Traction Systems
 - j) Bell Canada 360 Specifications;
 - k) National Fire Protection Association (NFPA):
 - 1) NFPA 70 National Electrical Code;
 - 2) NFPA 70E and CSA Z462;
 - 3) NFPA 13-2010, Standard for the Installation of Sprinkler Systems; and
 - 4) NFPA 14-2013, Standard for the Installation of Standpipe and Hose Systems.
 - l) Canadian Standards Association (CSA):
 - 1) CSA Z321 Signs and Symbols;
 - 2) CSA Z462 Workplace electrical safety;
 - 3) CAN/CSA B149. Natural Gas and Propane Installation Code;
 - 4) CAN/CSA - C22.3 No.6-91 Coordination between Pipelines and Electrical Supply;
 - 5) Ontario Electrical Safety Code (OESC) CSA C22.1; and

- 6) Canadian Electrical Code (CEC) CSA C22.1
- m) 1-2015, Natural Gas and Propane Installation Code;
- n) Canadian General Standards Board (CGSB);
- o) Canadian Gas Association (CGA);
- p) CAN/CGSB 24.3-92, Identification of Piping Systems;
- q) Master Painters Institute (MPI) - Architectural Painting Specifications Manual;
- r) Canada Green Building Council (CaGBC);
- s) The International Standard ISO/IEC TR 14763-2-1;
- t) Radio - Motorola-R56 standard; and
- u) LEED Canada-NC, LEED (Leadership in Energy and Environmental Design): Green Building Rating System Reference Package for New Construction and Major Renovations with addenda.

2. EXECUTION

2.1. PRINCIPLES

- 2.1.1. The minimum requirements and principles which apply to electrical labelling and identification are:
 - a) Identify raceway pathways, cables and equipment as outlined in the GO Design Requirements Manual, and Metrolinx Standard Specifications and Drawings;
 - b) Where impracticable to obtain equipment prefinished in coded colours, equipment may be site painted or tagged with coded colours. Coordinate with other work;
 - c) Label cables, cords, power strips, cabinets, electrical raceways, grounding conductors, outlets, faceplates, firestops in accordance with latest revision of TIA-606 and as described herein;
 - d) Identify conduits, electrical raceways, pull boxes, junction boxes, for Electrical and communications according to the colour scheme indicated herein and in the GO Design Requirements Manual;
 - e) Identify cables, outputs, faceplates, jacks, grounding components and cabinets for electrical and communications according to the labelling and identification scheme indicated herein and in the GO Design Requirements Manual;

- f) Use cables, jacks, cords, icons, manufactured in the colours identified herein; and
- g) Use the identification schemes as indicated.

3. IDENTIFICATION

3.1. LABELLING

3.1.1. Use the following identification standard when labelling components:

- a) Include required cabling designations on the drawings;
- b) Use Metrolinx abbreviations identified within this document;
- c) Use the layout of the information as shown in this section using symbols (Table 1) in the appropriate locations; and

Table 1: Symbols

Symbol	Explanation
+	Next portion of the identifier is a location
=	Specifies a function aspect
-	Separates different portions of equipment identifiers
:	Suffix portion of equipment identifiers (ex. Circuit number)
.	Separates the portion of the identifier for the space, from the equipment
[]	Identifies a value
_	Identifies a particular location within a larger area or space

- d) The identification shall incorporate, but is not limited to the following information:
 - 1) System;
 - 2) Site location for equipment;
 - 3) Source and destination;
 - 4) Cable ends;
 - 5) Termination;
 - 6) Locations in panels;
 - 7) Patch panels or racks;

- 8) Ports;
- 9) Portholes;
- 10) Boxes;
- 11) Splitters;
- 12) Multiplexers; and
- 13) Servers.

3.2. SITE LOCATION AND SPACES

Table 2: Site/ Destination Table

Symbol	Site Source/ Destination Table
BR	Bridge
CC	Communications Closet
CAT	Catenary
COR01	Service Corridor (1...n) depending on quantity
DWA	Designated Waiting Area
ELECCL	Elevator Control Closet
ELEV1	Elevator (1...n) depending on quantity
EMR	Elevator Machine Room
ERR	Emergency Response Room
ES	Electrical Closets
ETA	Escalator Truss Access
FRVV RM	Fire Valve Room
HUB	Communication Hub Room
HV-SWGR RM	High Voltage Switchgear Room
JAN RM	Janitor Room
MAINT	Maintenance Room
MECH	Mechanical Room
MEL	Main Electrical Room
MHC	Manhole Communications
MHE	Manhole Electrical
MULPRS RM	Multipurpose Room

OF WC	Operator Washroom (Female)
OM WC	Operator Washroom (Male)
OPLN	Operator Lunchroom
PF WC	Public Washroom (Female)
PARK01	Parking Garage Floor (1...n) depending on quantity
PLAT01	Platform (1...n) depending on quantity
PM WC	Public Washroom (Male)
RETAIL	Retail Space
SEL	Sub Electrical Room
SHEL1	Shelters (1...n) depending on quantity
SF WC	Staff Washroom (Female)
SM WC	Staff Washroom (Male)
SS	Substation
STA	Station Ambassador Office
STAIR01	Stairs (1...n) depending on quantity
STO RM	Storage Room
TC/SGNL RM	Train Control/Signal Room
TEL RM	Telephone Room
TPSS	Traction Power Sub-station
Track EB	Track Eastbound
Track WB	Track Westbound
TVS ELEC RM	Tunnel Ventilation System Electrical Room
TVS FAN RM	Tunnel Ventilation System Fan Room
TVS SHFT/PSRF	Tunnel Ventilation System Shaft/Piston Relief
UWC	Universal Washroom
VFD	Variable Frequency Drive Room

Table 3: Function table

Symbol	Function Table
BAS	Building Automation System
CCTV	Closed Circuit Television

COMM	Communication
CTRL	Control
CQD	Card Query Device
CR	IAC Card Reader
EAS	Emergency Alarm Station
ELEC	Electrical
ELEV	Elevator
EMP	Emergency Management Panel
ESC	Escalator
FA	Fire Alarm
FEC	Fire Equipment Cabinet
GIDS	Guideway Intrusion Detection System
HVAC	Heating Ventilation and Air Conditioning
HT	Heat Tracing
IAC	Intruder Access Control
IADS	Information and Advertising Display Systems
JB	Junction Box
LCP	Local Control Panel
LTG	Lighting
MECH	Mechanical
PA	Public Address
PESB	Passenger Emergency Stop Button
RtE	Request to Exit
SCADA	Supervisory Control and Data Acquisition
TVS	Tunnel Ventilation System
UC	Utility Cabinet
UPS	Uninterrupted Power Supply

3.2.1. A unique identity shall be provided for each, but not limited to the following site structures:

- a) Shelter;
- b) Kiosk;

- c) Bunker;
- d) Bungalow;
- e) Parking structure;
- f) Bridge;
- g) Tunnel;
- h) Platform;
- i) Rooms and stationary identifiers (e.g. Structural columns);
- j) Poles;
- k) Manholes;
- l) Hand Holes;
- m) Pull pits;
- n) Chambers;
- o) Roofs;
- p) Floors; and
- q) Sublevels.

3.2.2. Identification labels bearing identifying names and numbers shall be provided for each but not limited to the following spaces:

- a) Powerhouses;
- b) Bungalows;
- c) Service buildings/ service cabinets;
- d) Substations ;
- e) Electrical equipment rooms /communication equipment rooms;
- f) Tunnels; and
- g) Bridges.

3.3. EQUIPMENT AND PANELS

3.3.1. In addition to the manufacturers' information (i.e. voltage, number of phases, alternating current, direct current, amperage etc.) a unique identity shall be provided for each, but not limited to the following equipment : acceptable approval sticker, site level location and information provided for each, equipment name, identify each subdivision of components:

- a) Switchboard;
- b) Switchgear;
- c) Motor Control Centres (MCC);
- d) Splitters;
- e) Panels;
- f) Racks;
- g) Pumps;
- h) Boilers;
- i) Air conditioners;
- j) Air compressors;
- k) Automatic transfer switch;
- l) Switch;
- m) Transceiver;
- n) Patch panel location;
- o) Manifold chamber;
- p) Lights;
- q) Cabinets/ splitters / boxes;
- r) Poles;
- s) Generator;
- t) Load Bank;

- u) Lighting control;
 - v) Uninterruptible Power Supply (UPS); and
 - w) Inverter.
- 3.3.2. A unique identity shall be provided for each, but not limited to the following equipment or load:
- a) Pump Boiler;
 - b) MCC;
 - c) Panel;
 - d) Board;
 - e) Switch; and
 - f) cabinet/Splitter/boxes.
- 3.3.3. Each panel shall have a label that indicates each circuit, its use, and load. Similarly, each piece of IT equipment (i.e. rack, port, server, etc.) shall follow ANSI/TIA 606B identification standards, ideology and nomenclature. Ensure that manufacturer's nameplates, CSA labels and identification nameplates are visible and legible at all times.
- 3.3.4. Nomenclature for equipment shall be denoted as follows:
- a) Site source location on site/room number:
 - 1) Site Source: Refer to Table 2; and
 - 2) Location on Site/Room Number: room number if available
 - b) Equipment Voltage, Equipment Type, Unique Alphanumeric Name:
 - 1) Equipment Voltage: 600=600VAC, 208=208VAC, 120=120VAC, 70=70VDC, 48=48VDC;
 - 2) Equipment Type: Refer Table 3; and
 - 3) Unique Alphanumeric Name: Refer to Table 13 - Abbreviations.
- 3.4. RACEWAY, PIPE, TRAY, THROUGH AND PATHWAY**
- 3.4.1. Raceways and pipes shall be colour coded.
- 3.4.2. Box covers and its fittings shall be pre-painted.

3.4.3. Conduits shall be tagged using the following convention:

- a) + (Site source _ location on site/ room number). (panel/ pole/box/ splitter/ equipment): (circuit number) = (conduit function) - (conduit voltage) - (conduit number + (site destination _ location on site/ room number). (panel/ pole/ box/ splitter/ equipment): (circuit number):
 - 1) Site Source: Refer to Table 2;
 - 2) Location on Site/ Room Number: room number if available;
 - 3) Panel/ Pole/ Box/ Splitter/ Equipment: origin of the conduit such as panels, transformers, switchgear, etc;
 - 4) Circuit Number: associated with the source equipment;
 - 5) Conduit Function: Refer to Table 3;
 - 6) Conduit Voltage: 600 = 600 VAC, 208 = 208 VAC, 120 = 120 VAC, 70 = 70 VDC, 48 = 48 VDC;
 - 7) Conduit Number: Each segment in a conduit run shall have a unique number. For long conduit runs that contain junction boxes/ pull points, the sources and destinations shall change with each segment;
 - 8) Site Destination: Refer to Table 2;
 - 9) Location on Site/ Room Number: room number if available;
 - 10) Panel/ Pole/ Box/ Splitter/ Equipment: destination of the conduit such as panels, transformers, switchgear, etc;
 - 11) Circuit Number: associated with the destination equipment; and
 - 12) Refer to section 10 for examples.

3.4.4. Raceways and pipes shall indicate the type of service provided by labels, colours and other important operational and safety information. The method of identification is as follows:

- a) Use wrap around identification bands to identify conduit where paints are impracticable or prohibited or have potential to damage cabling or adjacent materials. Avoid obscuring labels. Avoid obscuring inspection windows;
- b) Use wrap around identification bands to identify exposed electrical and communications cabling according to system and are to be indicated on the drawings;

- c) Apply one or more markings per the table below as indicated in the contract drawings. Apply a base mark of minimum 19 mm wide. Where indicated, apply stripes of minimum 8 mm (maximum 12 mm) each. Apply marking with separation of 12 mm to 20 mm between adjacent;
- d) bands. Apply the base marking band nearest to the junction of the conduit with the junction;
- e) box, outlet box or pull box;
- f) The frequency of the identification shall be not more than 1.5 m (5 feet) for above grade raceways or pipes; and
- g) The identify of all conduits required to run local services for signals, fans, pumps, heaters, switches, etc., shall identify all required for the 30% minimum spare conduits. Spare raceway and pipe shall be identified, and identification changed once filled or put in service.

3.5. TRACTION POWER AND HIGH VOLTAGE RACEWAY

- 3.5.1. Traction Power and High Voltage Raceway identification shall follow the general identification systems as detailed in this document unless instructed otherwise by Metrolinx.

3.6. CABLE TRAY

- 3.6.1. The cable trays use shall be restricted to radio towers between bunker and tower within system buildings, across pedestrian bridges and rooms (i.e. bungalows, bunkers, electrical/ communication, and control rooms).
- 3.6.2. The cable trays shall have the colour and frequency as spelt out for conduits.

3.7. CABLE TROUGH

- 3.7.1. The cable trough identification shall comply with the following requirements:
 - a) Cable troughs shall be colour and label identified as per the conduit and manhole handhole sections. The covers shall be identified as per power levels, system, and type;
 - b) The cable trough heavy duty, vehicle traffic rated, complete with "knock-out" holes or "t" configurations, exterior below grade use, resistant to sunlight exposure and suitable for use in wet locations shall have label identification. Individual cable trough sections shall interlock together to make a continuous cable trough without gaps colour identified;

- c) The cable trough shall have integral dividers to maintain separation between power and communication cables. These dividers shall identify the type of system on each side of the divider. Cables shall only enter or exit the cable trough through cable trough hand holes or pull boxes that are an integral part of the cable trough system. The cables entering or exiting shall be labelled and identified;
- d) The cable trough shall be placed in a level trench only when underground raceways are not practical or feasible. Power and communications cannot be run in the same trough. The trough is to be installed per manufacturer recommendations by qualified personnel. The manufacturers information labelling shall be part of the cable trough;
- e) Design of the cable trough system is to be approved by Metrolinx or it's representative prior to installation;
- f) Any additional modifications to the trough design at any time must have Metrolinx approval;
- g) Troughs are to meet Manufacturer's recommendations for cable fill and installation; and
- h) Refer to Metrolinx Specification 26 05 34 - Raceway for Electrical Systems for further details.

3.8. CONDUITS USED FOR BACKBONE CABLING

3.8.1. Identification of conduits for backbone cabling shall comply with the following requirements:

- a) Identify communications, electrical ducts, and mechanical ducts devices;
- b) Mark surface mounted metallic or non-metallic conduit raceways by use of a combination of coloured couplers and painted stripes, electrical identification plastic tape, or wrap-around markers;
- c) Do not identify surface raceways mounted below ceiling line in finished areas unless instructed otherwise. Do not apply colour code identifier markings to outlet faceplates in those areas unless instructed to do so;
- d) Identify raceways at termination of raceway and transition to other raceways or enclosures; and
- e) Apply markings on each side of transit through architectural partitions or floors or ceilings.

3.8.2. Conduits shall be labelled using the following convention:

- a) + (Site source _ location on site/ room number). (panel/ pole/ box/ splitter/ equipment): (circuit number) = (conduit function) - (conduit voltage) - (conduit number + (site destination _ location on site/ room number). (panel/ pole/ box/ splitter/ equipment): (circuit number):
- 1) Site Source: Refer to Table 2;
 - 2) Location on Site/ Room Number: room number if available;
 - 3) Panel/ Pole/ Box/ Splitter/ Equipment: origin of the conduit such as panels, transformers, switchgear, etc;
 - 4) Circuit Number: associated with the source equipment;
 - 5) Conduit Function: Refer to Table 3;
 - 6) Conduit Voltage: 600 = 600 VAC, 208 = 208 VAC, 120 = 120 VAC, 70 = 70 VDC, 48 = 48 VDC;
 - 7) Conduit Number: Each segment in a conduit run shall have a unique number. For long conduit runs that contain junction boxes/ pull points, the sources and destinations shall change with each segment;
 - 8) Site Destination: Refer to Table 2;
 - 9) Location on Site/ Room Number: room number if available;
 - 10) Panel/ Pole/ Box/ Splitter/ Equipment: destination of the conduit such as panels, transformers, switchgear, etc;
 - 11) Circuit Number: associated with the destination equipment; and
 - 12) Refer to Section 10 for examples.

3.9. ELECTRICAL EQUIPMENT

3.9.1. Identification of Electrical Equipment shall comply with the following requirements:

- a) (Site source _ location on site/room number) (Equipment Voltage, Equipment Type, Unique Alphanumeric Name):
- 1) Site Source: Refer to Table 2;
 - 2) Location on Site/ Room Number: room number if available;
 - 3) Equipment Function: Refer to Table 3;
 - 4) Equipment Voltage: 600 = 600 VAC, 208 = 208 VAC, 120 = 120 VAC, 70 = 70 VDC, 48 = 48 VDC;

- 5) Unique Alphanumeric Name: Refer to Table 13 - Abbreviations; and
 - 6) Refer to examples in Section 10.
- 3.9.2. Place identifying labels on each cell or cubicle of electrical equipment, comprised of several cells or cubicles such as switchgear and uninterruptible power supply (UPS).
- 3.9.3. Identify equipment in the main electrical rooms with lettering a minimum of 13 mm high.
- 3.9.4. Provide high voltage equipment with warning signs, suitably engraved to meet the requirements of inspection authorities.
- 3.9.5. Where wording is not specified in the Contract Documents, obtain the required wording from Metrolinx.
- 3.9.6. Supply and install identification nameplates on equipment, such as but not limited to circuit breakers, cells in an MCC, safety switches, panelboards, and pushbutton stations.
- 3.9.7. Mount and maintain a type written circuit directory, with clear plastic cover, on the inside of each panelboard door or cell, indicating the breaker or switch circuit number, rating, load description and load data, and panel number.
- 3.9.8. Nameplates Use of Colours as following:
- a) Conduits, boxes, splitters and Panels Electrical equipment shall be prefinished in coded colours designating voltage or system as indicated in Table 1 - Equipment Identification Schedule and Table 2 - Voltage Colour Identification for Line Voltage Equipment; and
 - b) Where impracticable to obtain equipment prefinished in coded colours, equipment may be site painted in coded colors. Coordinate with other work.

Table 4: Equipment identification table

Equipment	Colour	Nameplate Identification
Main Distribution Centre	Voltage Colour	Building name, consulting engineer, date installed, amp, volt
		Main breaker, Metering cabinet
		Instrument transformer enclosure
		Loads controlled by each over current protective device
		Metering devices
Distribution Centre	Voltage Colour	Distribution centre designation, amperage, and voltage

		Loads controlled by each overcurrent protective device
Panel boards	Voltage Colour	Panel board designation
MCC	Voltage Colour	MCC designation, amperage and voltage
		Relay terminal and transformer compartments
Manual Motor starters	N/A	Load controlled and mnemonics
Ground Bus	N/A	System Ground
On / Off Switches	N/A	Load controlled
Disconnect Switches	Voltage Colour	Voltage and equipment controlled and mnemonics
Transformers (XFMR)	Voltage Colour	XFMR designation, capacity, secondary and primary volt
Emergency Power Equipment	Voltage Colour	Designation and voltage
Wire ways	N/A	Voltage and system designation
Line Voltage	Voltage	Designation and voltage
Poles		Each pole shall have a unique id number above the electrical access hole stamped into the metal or pole material by the manufacture.
Low Voltage Cabinets and Enclosures	System Colour	System name; system name and number if more than one cabinet or enclosure
		Major components within cabinets and enclosures
Communications handholes and manhole		Two (2) markings ground into surface 24.5 mm apart on the entry and exit side of the manhole on the collar of the manhole or handhole. Inside manhole and handhole should be painted the handhole or manhole number.

Power handholes and manhole		No markings on the collar of the manhole or handhole. Inside manhole and handhole should be painted the handhole or manhole number.
Outlet: Data, clocks, radio, fair system, video, telephone and PA		
Outlet to power communication equipment		

Table 5: Voltage Colour Identification for Line Voltage Equipment

Voltage	Colour (in boxes and in ducts)	Colour of Wire
Fibre 0 V	Bronze	Blue = Ungrounded DC power Blue/ white stripe = DC grounded voltage white with blue tracer = DC common
12 V, 24 V, 120 VDC	Blue	Red = AC 3 Ph - phase A Black = AC 3 Ph - phase B Blue = AC 3 Ph - phase C (neutral White)
120/ 208 V, 120/ 240 V/ under 300 VAC	Grey	Red, black & blue with yellow tracer (neutral White)
120/ 208 V, 120/ 240 V or under 300 VAC emergency:	Grey with auxiliary Red	
347/ 600 V up to 600 V	Sand	Brown = AC 3 Ph - phase A Orange = AC 3 Ph - phase B Yellow = AC 3 Ph - phase C (neutral White)
347/ 600 V emergency:	Sand with auxiliary Red	
High voltage (above 750 V):	Up to 5K; Yellow with auxiliary blue	

High voltage (above 5 KV):	Up to 15K; Black with auxiliary Yellow	
High voltage (above 15 KV):	Up to 30K; Black with auxiliary Orange	

3.10. PULL AND JUNCTION BOXES

3.10.1. Identification of Pull and Junction Boxes shall comply with the following requirements:

- a) Identify pull boxes, terminal cabinets and junction boxes enclosing cables or connections with nameplates indicating: + (Site source _ location on site/room number). (box/ splitter/ conduit/ equipment): (circuit number) = (box function) - (box voltage) - (box number) + (site destination _ location on site/ room number). (box/ splitter/ conduit/ equipment): (circuit number):
 - 1) Site Source: Refer to Table 2;
 - 2) Location on Site/ Room Number: room number if available;
 - 3) Panel/ Pole/ Box/ Splitter/ Equipment: origin of the conduit such as panels, transformers, switchgear, etc;
 - 4) Circuit Number: associated with the source equipment;
 - 5) Box Function: Refer to Table 3;
 - 6) Box Voltage: 600 = 600 VAC, 208 = 208 VAC, 120 = 120 VAC, 70 = 70 VDC, 48 = 48 VDC;
 - 7) Site Destination: Refer to Table 2;
 - 8) Location on Site/ Room Number: room number if available;
 - 9) Box/ Splitter/ Conduit/ Equipment: destination of the conduit such as panels, transformers, switchgear, etc;
 - 10) Circuit Number: associated with the destination equipment; and
 - 11) Refer to section 10 for examples

- b) Provide junction boxes, relay panels and miscellaneous equipment energized from two (2) or more sources with warning nameplate prominently displayed, noting the number and location of the sources and their voltage;
- c) Identify pull and junction boxes over 100 mm size as follows:
 - 1) Use boxes which are prefinished in coded colours, or spray paint inside and outside of boxes prior to installation, in coded colours designating voltage or system;
 - 2) Apply size 2 lamacoid nameplates to cover for each box. Refer to Section 10 example 3 for an example junction box label;
 - 3) For pre-existing outlets, junction and pull boxes, apply a small area of paint to the inside;
 - 4) Apply identifying mark as paint to full surface of junction box and pull box cover panels for boxes of 150 x 150 mm or smaller;
 - 5) Legend - See Table 5 including conduits, boxes, splitters and panels above; and
 - 6) Label each cable at both ends with source and destination addresses and at the entrance and exit points of the Junction Box, Pull Box & Panels using Wire Identification Materials.

3.11. RECEPTACLES, FIRE ALARM AND DUCT RESISTORS

- 3.11.1. Standard duplex receptacles: provide lamacoid name tag with 6 mm high white lettering on black background (red background for emergency receptacles), indicating circuit and panel designation and locate on wall above receptacle. On all other receptacles provide nametag indicating voltage, phase, amps, and circuit and panel designations.
- 3.11.2. Fire alarm end-of line resistors & duct detectors: Identify zone number with 6 mm high white lettering on red background on Lamacoid nametag located on wall above device. Identify remote LED indicators for duct detectors.

3.12. UNDERGROUND WARNING TAPE

- 3.12.1. Underground warning tape shall be yellow ribbon type.
- 3.12.2. Underground conduits shall use underground warning tape. Install one tape per trench at 75 mm (3 in) below finish grade.

3.13. MANHOLE AND HANDHOLE MARKERS

3.13.1. Electrical and Communication manhole or handhole collars shall be provided with a single and two grooves respectively with minimum of 3 mm deep and 25 mm apart in the direction of the conduits entering and exiting the manhole or handhole.

3.14. NAMEPLATES

3.14.1. Nameplate identification shall comply with the following requirements:

- a) Panels and racks:
 - 1) Identify by plastic laminate, 3 mm thick melamine, matt white finish core, square corners, lettering accurately aligned and engraved into core;
 - 2) Sizes: 25 x 67 mm minimum;
 - 3) Lettering: minimum 7 mm high, white; and
 - 4) Inscriptions: machine engraved to identify function.
- b) Ensure the manufacturer's nameplates and authority approval (CSA, ULC, or TH and ESA) labels are visible and legible at all times after equipment installation;
- c) Nameplates on equipment served from emergency power/UPS shall have white letters on a red background;
- d) Nameplates for breakers in 208/120 V distribution boards or panelboards serving fire alarm/detection systems shall have white letters on a red background;
- e) Equipment and component nameplates: black letters on a white background;
- f) Warning and emergency power source equipment nameplates: White letters on a red background;
- g) Wording on nameplates shall be accepted by Metrolinx prior to their manufacture; and
- h) Securely fasten nameplates to equipment and substrates with self-tapping stainless-steel screws.

3.15. NAMEPLATES FOR FIELD DEVICES

3.15.1. Nameplates for field devices shall comply with the following requirements:

- a) Identify by plastic encased cards attached by chain to equipment, valves etc.;
- b) Sizes: 50 x 100 mm minimum;

- c) Lettering: minimum 5 mm high produced from laser printer in black;
- d) Data to include point name and point address (including ip address); and
- e) Companion cabinet: identify interior components using plastic enclosed cards with point name and point address.

3.16. COVER PLATE

3.16.1. For cover plate identification refer to Table 6 - Wall Jack Colour Standards below:

Table 6: Wall Jack Colour Standards

Use	Colour
Data / Corporate Network	Blue
Telephone	Blue
Radio Data / Communication	Orange

3.17. NAMEPLATES FOR ROOM SENSORS

3.17.1. Nameplates for room sensors shall comply with the following requirements:

- a) Identify by stick-on labels using point identifier;
- b) Location: as directed by Metrolinx's representative; and
- c) Letter size: to suit, clearly legible.

3.18. WARNING SIGNS

3.18.1. Supply and install orange coloured warning signs warning of automatic starting under control of computerized automatic control system (e.g. BAS, SCADA, Energy Management System) for equipment including motors and starters under remote automatic control.

3.18.2. Warning signs shall read: "Caution: This equipment is under automatic remote control of XXXX". Where XXXX is the System controlling the Equipment.

3.18.3. For Arc Flash Warning Signs and Boundaries all equipment identified in the Arc flash Study Report shall have the required sign installed.

3.19. SYSTEM COLOURS

3.19.1. Employ system colours as indicated in Table 7 below as a minimum:

Table 7: System Colour Identification for Low Voltage Systems Equipment

Number	Systems	Colour (in boxes and in ducts)
1	Evacuation, Fire Alarm and Fire Telephone, Emergency Call, Fireman’s Emergency power off	Red emergency Voice red/blue
2	Security, Card Access and Security TV	Yellow Red / Yellow
3.	Telephone Cabinets	Brown
4	CCTV and TV Distribution	Brown
5	Intercom System	Brown
6	Public Address	Brown
7	Mobile Radio	Brown
8	All other communications	Green / Blue
9	Building automation, Computer & Data systems	Purple
10	Clock System	Purple
11	Digital information Signage	Purple
12	PRESTO	Pink
13	Dedicated Ground	Green

3.20. PNEUMATIC TUBING

3.20.1. Number tape marking on tubing to provide uninterrupted tracing capability.

3.21. COPPER WIRE, FIBRE STRAND, AND CABLE IDENTIFICATION

3.21.1. Use the following identification standard when labelling communications cabling components. Include required cabling designations on the drawings.

3.21.2. Back Bone Fibre.

3.21.3. Minimum number of strands of a backbone cable shall be no less than 24 strands. All fibers shall be terminated. Refer to Table 8 below for recommended colour identification. Refer to Metrolinx I&IT Standards Document for specific requirements.

Table 8: Backbone Cables

Meaning	Buffer/ Jacket Colour
Single-mode optical fibre	Yellow

10 gig laser-optimized 50/125 micrometer multi-mode optical fibre	Aqua
Sometimes used to designate polarization-maintaining optical fibre	Blue

3.22. PATCH COPPER CABLE COLOUR STANDARDS

- 3.22.1. All copper patch cables being provided shall be Category 6 cables. Cable lengths shall be of reasonable length allowing for proper cable routing needed for a tidy and organized installation.
- 3.22.2. Each end shall have source and destination labelling complete with the colour code as specified in Table 9 below or as specified in the IT section of the DRM.

Table 9: Patch Copper Cable Colour Standards

Meaning	Buffer/ Jacket Colour
Data / Corporate Network PC / Printers / Telephone Sets	Blue
Corporate Servers	Red
Switch / Router Crossovers and Normal	Yellow
iLO / KVM / Management	Purple / Indigo

3.23. PATCH FIBRE CABLE COLOUR STANDARDS

- 3.23.1. All Fibre patch cables being provided shall be single mode matching the type of cable it is to be connect to. Cable lengths shall be of reasonable length allowing for proper cable routing needed for a tidy and organized installation.
- 3.23.2. Each end shall have source and destination labelling complete with the colour code as specified in Table 9. Refer to Metrolinx I&IT document for specific requirements.
- 3.23.3. Wires shall have a colour code as detailed below indicating the following:
 - a) Voltage levels;
 - b) Direct or alternating current; and
 - c) Colour coding standards for the particular type of strand or wire identification
- 3.23.4. Strand and wires shall have the following label information:
 - a) IP address if applicable;

- b) System identification if applicable;
- c) Site source and destination identification:
 - 1) A source is defined as the termination point that the power or signal is supplied from and the cable end connects to. The destination is defined as the other end of the cable or wire terminates at or splits into more than one wire or signal source. The destination may be, but not limited to: splitter, lights, Motor; monitor, speaker, amplifier, pump, transceiver, server, multiplexers, etc. The source and destination information shall be separated by following punctuation a "/". The ":" is to be used separating information like location, panel or rack etc. The order of the information layout shall be consistent.
- d) Spare wire or strands shall have an identification for the spare plus a unique id and source and destination information;
- e) Installing contractor to supply and install numbered tape markings on wiring at panels, junction boxes, splitters, cabinets and outlet boxes; and
- f) Labels for equipment, (e.g. Panel, rack, MCC, circuit/port, disconnect, breaker/fuse, cover plate, loads, termination point) shall include information such as the following:
 - 1) IP address if applicable;
 - 2) System identification if applicable;
 - 3) Unique device name;
 - 4) Voltage, phase information; and
 - 5) Warning signs.

3.24. POWER AND COMMUNICATIONS CABLES

- 3.24.1. Use of colour coded wiring for power and communications cables, shall be consistent and be matched throughout the systems.
- 3.24.2. Labelling nomenclature shall be consistent for identifying where the cable begins on the site, including information like equipment, rack, board, panel etc. And where the cables end on site, complete with information like fire breaks, passed through, the box, receptacle, light, equipment, terminal, patch panel or panel, etc. at each end of the cable. The layout of the information shall be consistent with standard set punctuation and separators. The information shall be at both ends of the wire or fibre. Spare wires and stands shall have a unique identifier indicating it is a spare with source and destination identification.

- 3.24.3. Power wiring: identify circuit breaker panel/ circuit breaker number inside each panel or rack.
- 3.24.4. Panel and rack schedules, single line diagrams, and riser drawings shall be provided in electrical and communication rooms.
- 3.24.5. Cabling Format
- a) + (Site source _ location on site/room number). (panel/ pole/ box/ splitter/ conduit/ equipment): (circuit number) = (cable function) - (cable voltage) - (cable number) + (site destination _ location on site/ room number). (panel/ pole/ box/ splitter/ conduit/ equipment): (circuit number):
- 1) Site Source: Refer to Table 2;
 - 2) Location on Site/ Room Number: room number if available;
 - 3) Panel/ Pole/ Box/ Splitter/ Equipment: origin of the conduit such as panels, transformers, switchgear, etc;
 - 4) Circuit Number: associated with the source equipment;
 - 5) Cable Function: Refer to Table 3;
 - 6) Cable Voltage: 600 = 600 VAC, 208 = 208 VAC, 120 = 120 VAC, 70 =70 VDC, 48 =48 VDC;
 - 7) Cable Number: Each segment in a conduit run shall have a unique number. For long conduit runs that contain junction boxes/ pull points, the sources and destinations will change with each segment;
 - 8) Site Destination: Refer to Table 2;
 - 9) Location on Site/ Room Number: room number if available;
 - 10) Panel/ Pole/ Box/ Splitter/ Equipment: destination of the conduit such as panels, transformers, switchgear, etc; and
 - 11) Circuit Number: associated with the destination equipment.

4. BACKBONE

4.1. INTRA-BUILDING BACKBONE CABLING

- 4.1.1. Cables that run within one electrical or telecommunication room or extend between two or more sub electrical rooms or closets, or between sub telecommunication rooms, hub rooms or closet within a building are called intra-building backbone cables.

- 4.1.2. A unique backbone cable identifier shall be assigned to each backbone cable between two rooms or closets in one building and it shall have a format of as follows:
- a) An identifier for the space containing the termination of one end of the backbone cable followed by identifier for the space containing the termination of the other end of the backbone cable;
 - b) The identifiers shall include one or two alpha-numeric characters identifying a single cable with one end terminated in the source and the other end terminated in the destination. This identifier should also include information on the end like floor location, followed by room or column identifiers; and
 - c) In this format, the identifier with the lesser alpha-numeric identifier shall be listed first. All intra- building backbone cable identifiers in a single infrastructure should have the same format where possible. The backbone cable identifier shall be marked on each end of the backbone cable within 300 mm (12 in) of the end of the cable jacket

4.2. INTER-BUILDING BACKBONE CABLING

- 4.2.1. Cables that run from an Electrical or telecommunication room in one building or structure and extend to two or more building or structure electrical or telecommunication rooms in another building are called inter- building backbone cables.
- 4.2.2. A unique inter-building backbone cable identifier shall be assigned to each backbone cable connecting terminations in different buildings, and it shall have the following structure:
- a) cable is terminated using a unique alpha-numeric characters identifier for each wire, stand or cable's end terminations;
 - b) The building with the lesser alpha- numeric identifier shall be listed first;
 - c) All inter-building backbone cable identifiers in a single infrastructure should have the same format where possible; and
 - d) The inter-building backbone cable identifier shall be marked on each end of the backbone cable within 300 mm (12 in) of the end of the cable jacket.

4.3. INTER-SITE BACKBONE CABLING

4.3.1. Cables that run through the rail corridor to support Metrolinx operations from Electrification Substations/ paralleling Stations, stations, Signal Bungalows, Cabinets, Electrical or telecommunication spaces interconnecting buildings or structures along the corridor and extend to two or more Metrolinx operations such as Substations/ paralleling Stations (electrification or signals or rail operation, stations, Signal Bungalows, Cabinets, Electrical or telecommunication spaces electrical or telecommunication rooms in another building are called inter-building backbone cables.

4.3.2. A unique inter-building backbone cable identifier shall be assigned to each backbone cable connecting terminations in different buildings, and it shall have the format structure as shown below:

- a) Cabling format: + (Site source _ location on site/ room number). (panel/ pole/ box/ splitter/ conduit/ equipment): (circuit number) = (cable function) - (cable voltage) - (cable number) + (site destination _ location on site/ room number). (panel/ pole/ box/ splitter/ conduit/ equipment): (circuit number):
- 1) Site Source: Refer to Table 2;
 - 2) Location on Site/Room Number: room number if available;
 - 3) Panel/Pole/Box/Splitter/Equipment: origin of the cable such as panels, transformers, switchgear, etc.;
 - 4) Circuit Number: associated with the source equipment;
 - 5) Cable Function: Refer to Table 3;
 - 6) Cable Voltage: 600 = 600 VAC, 208 = 208 VAC, 120 = 120 VAC, 70 = 70 VDC, 48 = 48 VDC;
 - 7) Cable Number: Each segment in a conduit run shall have a unique number. For long conduit runs that contain junction boxes/ pull points, the sources and destinations shall change with each segment;
 - 8) Site Destination: Refer to Table 2;
 - 9) Location on Site/ Room Number: room number if available;
 - 10) Panel/ Pole/ Box/ Splitter/ Equipment: destination of the cable such as panels, transformers, switchgear, etc;
 - 11) Circuit Number: associated with the destination equipment; and
 - 12) Refer to section 10 for detailed examples.

- b) Identifier as shown above shall be provide at each end of the backbone cable termination.
- c) Each end of the backbone cable is terminated using a unique identifier consisting of alpha-numeric characters for each wire, stand or cable's end terminations.
- d) The building with the lesser alpha- numeric identifier shall be listed first. All inter-building backbone cable identifiers in a single infrastructure shall have the same format.
- e) The inter-building backbone cable identifier shall be marked on each end of the backbone cable within 300 mm (12 in) of the end of the cable jacket. Refer to section 10 for detailed examples.

4.4. INTER-SITE BACKBONE CABLING FOR ELECTRIFICATION, IT AND SIGNALS

4.4.1. Power Raceways Identification

- a) Red colour markings for signalling conduit and red colour with stripes for Electrification conduits
- b) Communication Raceways Identification. Sizes for each below to be determined by project specific team.
- c) Orange colour (Express Fiber, Local Land, Spare), for Fiber Optic Signalling System
- d) Orange colour with different stripes (Express Fiber, Local Land, Spare), for Fiber Optic SCADA Electrification System
- e) Purple colour, for Corporate Network, Operation/Station, Leasing, and Communications System
- f) Brown colour, for Radio System.

4.4.2. Backbone Cabling Documentation Records shall comply with the following requirements:

- a) A copy of all backbone cable records shall be left in each of the electrical or Telecommunication room where the cable terminates. This shall be located nearest the cabling/ network rack and shall be placed in a self-adhesive plastic envelope. An electronic and a hard copy shall also be provided to Metrolinx. This shall be included with the testing and certification records of the installed cable;
- b) Identifier information in which one end of the backbone cable is terminated:

- 1) Identifier for the systems cable/ strand termination in which the other end of the backbone cable has one or more alpha-numeric characters identifying a single cable with site, structure, floor source and destination termination information. In this format, the site structure with the lesser alpha-numeric identifier shall be listed first;
 - 2) All inter-building backbone cable identifiers in a single infrastructure should have the same format where possible; and
 - 3) The inter-building backbone cable identifier source and destination shall be marked on each end of the backbone cable within 300 mm (12 in) of the end of the cable jacket.
- c) Sample Cable Report in Table 10:

Table 10: Sample Cable Report

Cable:	PG-01MCR/PG-03TR-01
Total Length:	330 m
Number of strands/ pairs:	6
Cable Type:	50/125 Single mode fiber Installation
Date:	March 12, 2011
	Device Connected/ Circuit#
01	
02	
03	
04	
05	
06	

4.4.3. For wire and box identification refer to Table 11 below:

Table 11: Wire and Box Identification: Voltage Level Colour for Line Voltage Equipment

Voltage	Colour	Voltage
Fibre O V	Bronze	
12V, 24V, 120 V dc	Blue	Blue = Ungrounded DC power Blue/white stripe = DC grounded voltage

		white with blue tracer = dc common
120/208 V/120/240 V / under 300V ac	Grey	Red = AC 3 Ph - phase A Black = AC 3 Ph - phase B Blue = AC 3 Ph - phase C (White =Neutral)
120/208 V 120/240 V: or under 300V ac emergency:	Grey with auxiliary Red	Red = AC 1 Ph - phase A Black = AC 1 Ph - phase B Blue = AC 3 Ph - phase C White =Neutral All with yellow tracer.
347/600 V Up to 600V	Sand	Brown = AC 3 Ph - phase A Orange = AC 3 Ph - phase B Yellow = AC 3 Ph - phase C (White = neutral)
347/600 V emergency:	Sand with and auxiliary Red	Brown = AC 3 Ph - phase A Orange = AC 3 Ph - phase B Yellow = AC 3 Ph - phase C (White = neutral) All with red tracer
High voltage (above 750 V):	White with a Black stripe up to 5K Yellow with auxiliary blue	
High voltage (above 5KV):	up to 15K; Black with auxiliary Yellow	
High voltage (above 15 KV):	up to 30K; Black with auxiliary Orange	

5. DIFFERENT SYSTEMS IDENTIFICATION REQUIREMENTS

5.1. METROLINX SUBGROUPS

5.1.1. Metrolinx have several subgroups which have special identification requirement. These groups are as listed below but are not limited to the following list:

- a) Bus Systems Terminal and Mobility Hubs Facilities Maintenance; and
- b) Rail Systems which has the following sub groups:
 - 1) Electrification;
 - 2) Signals;

- 3) Rail operations and maintenance facilities; and
- 4) Rail stations, parking facilities and office structures.

5.2. SYSTEM NAMEPLATES

5.2.1. System Nameplates shall comply with the following requirements:

- a) Hazardous: red letters, white background; and
- b) Elsewhere: black letters, white background (except where required otherwise by applicable codes)

6. SUBMITTALS

6.1.1. The following shall be submitted in accordance with the contract documents submittal procedures:

- a) Manufacturer's Product data indicating, sizes, colours, identification systems and fasteners;
- b) Product transportation, storage, handling and installation requirements; and Equipment schedule indicating equipment location (including room number), service, identifier, nameplate type and nameplate colour; and
- c) Samples of each type of identification product used.

7. TYPICAL NAME PLATE SIZES

7.1.1. Make name plates 250 mm x 175 mm at a minimum unless otherwise specified. Refer to Table 12 below for nameplate sizes.

Table 12: Name Plate Sizes

Name Plate	Size (mm)	Line	Letter Height (mm)
Size 1	10 x 50	1	3
Size 2	12 x 70	1	5
Size 3	12 x 70	2	3
Size 4	20 x 90	1	8
Size 5	20 x 90	2	5
Size 6	25 x 100	1	12
Size 7	25 x 100	2	6
Size 8	25 x 125	2	6

Size 9	25 x 125	3	13
Size 10	35 X 100	3	5
Size 11	53 X 100	1	25
Size 12	60 X 160	3	8
Size 13	50 x 200	3	13
Size 14	35 x 200	1	20

8. STANDARD ABBREVIATIONS

8.1.1. Abbreviations in Table 13 below are a list of standard abbreviations for common terminology to be used on labels, markings, tags and signs.

Table 13: Abbreviations

Common Terminology	Abbreviation
12,000 BTUH (Cooling Capacity)	TON
208/240 V Switchboard	2SB
600 V Switchboard	6SB
600 V Switchgear	6SW
Above Finish Floor	AFF
Above Grade Floors	O-99
Above Top of Rail	ATR
Access Door	AD
Access Panel	AP
Adjustment	ADJ
Agent Release Panel	ARP
Air Vent	AV
Air circuit breaker	ACB
Air Compressor	AirC
Air Conditioning Package	A/C
Air Conditioning Unit	ACU
Air Damper	AirD
Air Foil	AF
Air Handling Unit	AHU

Air Hose Station	AHS
Air or Compressed Air	AIR
Air Pressure Drop	APD
Air Stream	AS
Along Track Movement	ATM
Alternating Current	ac
Aluminum Conductor Steel Reinforced	ACSR
Aluminum Wire Armour	AWA
Aluminum	AL
Aluminum Ground Wire Bare	AGWB
Aluminum Ground Wire Covered	AGWC
Ambient Temperature Correction Factor	Ca
American Society for Testing and Materials	ASTM
American Wire Gauge	AWG
American National Standards Institute	ANSI
American Public Transportation Association	APTA
American Railway Engineering and Maintenance -of-Way Association	AREMA
American Society of Heating, Refrigerating and Air-Conditioning Engineers	ASHRAE
Ampere	AMP
Ampere Interrupting Capacity	AIC
Amperes	A
Antennae	ANT
Arc Fault Circuit Interrupter	AFCI
Area	AREA
Association of American Railways	AAR
Atmosphere	ATM
Automatic Control Damper	ACD
Automatic Temperature Control	ATC
Automatic Transfer Switch	ATS
Automatic voltage regulator	AVR
Autotransformer	AXFMR

Autotransformer Feeder	ATF
Autotransformer Feeder Zone	ATFZ
Auxiliary Control Relay	CR
Auxiliary Transformer	AT
BACK BONE CABLE	BBC
Back Draft Damper	BDD
Backflow Preventer	BFP
Backwards Inclined	BI
Balance Weight Anchor	BWA
Basement	BSMT
Bayonet Cap	BC
Bell Demarcation	BELLD
Boiler	BLR
Boiler Snow Melt	BSM
Bonding /ground fault loop impedance	Zs
Bonding /ground leakage circuit breaker	ELCB
Bonding /ground loop impedance external to installation	Ze
Bonding /grounded equipotential bonding & automatic disconnection	EEBAD
Bonding /grounding system T =Direct Connection to the Earth N = Neutral or ground connection to the supply S = Separate C = Combined I = Isolated or High impedance to ground	IT, TN-S, TN-C-S, TT,TN-C
Bonding /grounding system	TN-S
Bottom of Duct	BOD
Brake Horsepower	BHP
Bridges	BRDG
British Thermal Units	BTU
BTU per Hour	BTUH
Building (crew, office, maintenance, warehouse, etc....)	Bldg
Building Automation System,	BAS

Bungalows	BUNG
Bunkers	BUNKR
Burglar Alarm Panel	BAP
Cabinet Unit Heater	CUH
Data (Copper) Outlet	C
Cabinets	CAB
Cable	CA
Communications Closet	CC
Cable Grouping Correction Factor	Cg
Cable Television or Community Antennae Television	CATV
Cable Termination Cabinet	CTC
Canadian Electrical Code	CEC
Canadian National	CN
Canadian Pacific	CP
Canadian Spatial Reference System	CSRS
Canadian Standards Association	CSA
Candela	CD
Car Counting System	CCS
Carbon Dioxide	CO2
Carbon Monoxide	CO
Cogeneration Power	COG
Catenary	CAT
CCTV Camera	TVC
CCTV Control Cabinet	CCTV
Center or Centrifugal	CENT
Central Processor Unit	CPU
Centre Line	CL
Certified Ballast Manufacturer	CBM
Check - Valve	CV
Chilled or Chiller	CH
Chilled Water	CHW
Chilled Water Return	CHWR

Chilled Water Supply	CHWS
Circuit (also: CCT, CKT, CIR)	CIR
Circuit Breaker	C/B
Circuit Protective Conductor	CPC
Clearance	CLR
Closed Circuit Television	CCTV
Closed Circuit Television Cabinets	CCTVC
Closed Circuit Television Rack	CCTVR
Code System Charger	CSC
Co-Generator	COG
Column	Cln
Combination Smoke/ Fire Damper	SFD
Colour Rendering Index	CRI
Combined Neutral and Bonding/ Ground	CNE
Combined Protective and Neutral	PEN
Communication	Com
Communications Backbone	ComB -
Communications Hub Room	HUB
Compressed Air	CPAir
Concentrator Complex	CC
Condensate Drain	Condensate
Condenser Unit	ACC
Condenser Water Return	CWR
Condenser Water Supply	CWS
Conductor Cross-Sectional Area	CCSA
Conduit	C
Connection	CONN
Contact Wire	CW
Contact Wire Height	CWH
Control	CONT
Control Cabinet	CC
Control Module (Fire Alarm/Detection)	CM

Control Panel	CP
Control Power Transformer	CPT
Cooling Tower	CTWR
Cooling Tower Blow Down	CTBD
Copper	CU
Copper Ground Wire Bare	CCWB
Copper Ground Wire Covered	CCWC
Correction Factor (conductor operating temperature)	Ct
Counter Poise	CPO
Counter Poise Wire Buried	CPWB
Cover Plate	CRP
Crawl Space	CSpc
Credit Query Device	CQD
Crime Prevention Through Environmental Design	CPTED
Critical Branch	CB
Cross-Sectional Area	c.s.a
Cubic Feet	CF
Cubic Feet per Minute	CFM
Current Carrying Capacity	Iz
Current Collector Zone	CCZ
Current Limiting Fuse	CLF
Current Setting of Protective Device	Ispd
Current to Operate Protective Device	Ia
Current Transformer	CT
Data/Instrumentation, Annunciation	D/IA
Decibel	dB
Dedicated Ground Zone	DGZ
Degree	DEG
Design Current	Ib
Designated Waiting Area	DWA
Design Requirements Manual	DRM
Diameter	DIA

Differential Pressure	DP
Digital Meter	DM
Dimension	DIM
Direct Current	DC
Direct Digital Control	DDC
Disconnect Switch	DS
Distribution	Dist
Distribution Panelboard	DP
Domestic Cold Water	DCW
Domestic Hot Water	DHW
DHW Re-Circulation Pump	DHW-P
Down Guy	DG
Down Guy Wire	DGW
Drain	D
Drinking Fountain	DF
Drawings	DWG
Dry Bulb (Temperature)	DryB
Dry Sprinkler	SPR-DRY
Dual Tone Multi-Frequency	DTMF
Each or Exhaust Air	EA
East Bound	EB
Edison Screw	EDS
Electric Traction	ET
Electric Vehicle Charging and Recovery Station	EVCS
Electric Water Cooler	EWC
Electrical	E
Electrical Closets/Sub Electrical Room	ES
Electrical Code or Electrical Contractor	EC
Electrical Contractors Association	ECA
Electrical Equipment Manufacturer's Association	EEMAC
Emergency Standby Generator	EG
Emergency Supply	ES-

Electrical Metallic Tubing	EMT
Electrical Safety Authority	ESA
Electrical Unit Heater	EUH
Electrical Utility Supply	EU
Electro-Magnetic Compatibility	EMC
Electro-Magnetic Interference	EMI
Electro-Motive Force	e.m.f.
Electronic Industries Alliance	EIA
Elevation	EL
Elevator 1 (1...n)	ELEV1
Elevator Machine Room	EMR
Emergency	EM/EMER
Emergency Alarm	EA
Emergency Distribution Panel	EDP
Emergency Generator	EG
Emergency Power	EP
Emergency Power Distribution Panel	PPE
Emergency Power Off (Button or Switch)	EPO
Empty Box	ZB
Empty Conduit /R	EC -
Energy Management System	EMS
Energy Recovery Ventilators	ERV
Entering Air Temperature	EAT
Entering Water Temperature	EWT
Environmental Protection Agency	EPA
Equipment Branch	EB
Equipment Ground Conductor	EGC
European Committee for Electrotechnical Standardization	CENELEC
Exhaust	EXH
Exhaust Air Handling Unit	EAHU
Exhaust Fan	EF
Expansion	EXP

Expansion Tank	ETK
External	EXT
External - Building Back Bone Cable	EBBC
External Static Pressure	ESP
Eye/Face Wash Station	EWS
Eyewash Tempering Unit	EWT
Fire Alarm Equipment	FA
Fire Alarm Detection	FAD
Fahrenheit	F
Fan Coil Unit	FCU
Fan Control Panel	FCP
Fault Current	Ifd
Federal Communications Commission	FCC
Data (fiber) outlet	FO
Federal Transit Administration	FTA
Fault Isolator Module (Fire Alarm/Detection)	FIM
Federal Railroad Administration	FRA
Feed Wire	FW
Feet	FT
Feet per Minute	FPM
Feet per Second	FPS
Fiberglass Reinforced Epoxy	FRE
Fiberglass Reinforced Plastic	FRP
Fibre multi-mode (source and destination on each end as a minimum) IP address of end device	FMM
Fibre Optic	FO
Fibre Optic Control Cabinet	FOCC
Fibre Optic Patch Panel	FOPP
Fibre Optic Splice Box	FOSB
Fibre single mode (source and destination on each end as a minimum) IP address of end device	FSM
Fin Tube Radiation	FTR
Fire Alarm	FA

Fire Alarm Annunciator (Fire Alarm Audible Device)	FAA
Fire Alarm Bell	FB
Fire Alarm Panel	FAP
Fire Alarm Visual Device	FAS
Fire Alarm/Detection & Suppression	FADS
Fire Extinguisher (Inside)	FE-1
Fire Hose Cabinet	FHC
Fire Hose Reel	FHR
Fire Fighter's Emergency Power OFF	FEPO
Fire Fighter's Handset	FFH
Fixed Termination Anchor	FTA
Flexible	FLEX
Flexible Connection	FC
Flexible Metal Conduit	FMC
Floor Drain	FLRDR
Floor Drain, Fire Damper, or Fire Department	FD
Floor Followed by either B9-B1 for Sub Grade Floors or 1 - 99 - for Above Grade Floors	FLXX
Flow Switch	FS
Fluid Dispenser - Compressed Air	Air
Forced Air Heater	FAH
Foundation	FDN
Free Area	FreeA
Frequency	f
Frequency Switch	FQ
Full Load Amperes	FLA
Functional Extra-Low Voltage	FELV
Funnel Floor Drain	FFD
Fuse	FU
Fuzzy Logic Control	FLC
Gallons	GAL
Gallons per Hour	GPH

Gallons per Minute	GPM
Galvanized	GALV
Galvanized Rigid Metal Conduit	GRMC
Gas	G
Gauge	GA
General	GENL
Glycol Feed Unit	GFU
Metrolinx Control Centre	GTCC
Grade	GR
Ground	GND
Ground Fault Circuit Interrupter	GFCI, GFI
Ground Plain	GRNDPL
Ground Plate	GRNDP
Grounding	GRN
Grounding and Bonding Wire	GBCW
Grounding System / Bonding	TT
Guidance Note	GN
Handhole	HH
Hand Well Communication	HHC
Hand Well Electrical	HHE
Hand-Off-Automatic Switch	HOA
Head	H
Heat Detector (Fire Alarm/ Detection)	HD
Heat Recovery Unit	HRU
Heat Tracing	HT
Heater/Heating Element Input	HTR
Heating	HTG
Heating Unit	HU
Heating, Ventilation, Air Conditioning	HVAC
Hertz (Cycles per Second)	Hz
Height	H/HT
High Breaking Capacity (Fuse)	HBC

Hollow Metal	HM
High Rail	HRL
High Voltage	HV -
Horizontal	Horiz
Horizontal Cable Labels (source and destination on each end as a minimum)	HC
Horsepower or High Point	HP
Hose Bib (Connection)	HB
Hot Water Return	DHW-R
Hot Water Tank	HWT
Hour	HR
Hub Drain	HD
Humidity Switch	HS
Inter-Building Back Bone Cable	IBBC
Illuminating Engineering Society	IES
Impedance (Electrical)	Z
Impedance Grounding	ZGRND
In Running	IR
Inches	IN
Indoor Air Quality	IAQ
Information Signage	IS
Information Technology	IT
Independent Electricity System Operator	IESO
Inside Diameter	ID
Institute of Electrical and Electronic Engineers	IEEE
Institution of Electrical Engineers	IEE
Insulated Gate Bipolar Transistors	IGBT
Interlock	INT
Intermediate Metal Conduit	IMC
International Electrotechnical Commission	IEC
Inverter	INTR
Isolated Ground	IG

Janitor Sink	JS
Joules	J
Joules per cm sq	J/cm ²
Jumper	JPR
Junction Box	JB
Kilo	k
Kilovolt (1000 V)	kV
Kilovolt-Amperes	KVA
Kilovolt-Amperes Reactive	KVAR
Kilowatt	KW
Kitchen Sink	KS
Leadership in Energy and Environmental Design	LEED
Lavatory	LAV
Layover Compressor Station	LCS
Layover Fueling Station	LFS
Layover Wayside Station	LWS
Leaving	LVG
Leaving Air Temperature	LAT
Leaving Water Temperature	LWT
Light Emitting Diode	LED
Light Rail Transit	LRT
Lighting	LTG
Lightning Arrestor	LA
Lighting Pole	LPL
Lightning Protection System	LPS
Limit Switch	LS
Linear Diffuser	LD
Linear Feet	LF
Lines of Three-Phase System	L1, L2, L3
Liquid Tight Flexible Metal Conduit	LFMC
Local Control Office	LCO
Local Control Panel	LCP

Lock Rotor Amps	LRA
Locomotive Wash	LWL
Long	LG
Lot	LOT
Louver	LUVR or LVR
Louvered Door	LVDR
Low Point	LP
Low Voltage (120VAC)	LV
Low Voltage (CCTV, Radio, LAN, Security)	L
Machine-Room-Less	MRL
Main Circuit Breaker	MCB
Main Ground Bar	MGB
Main Lugs Only	MLO
Main Telecommunications Room (Main Communications Room)	MC
Maintenance Facility	MF
Make-Up Air Unit	MUA
Make-Up Water	MU
Manhole	MH
Manual Pull Station	MP
Manual Transfer Switch	MTS
Maximum	MAX
Maximum Demand	MaxD
Mechanical Room	MECH
Medium Voltage	MV
Meg or Mega	M
Megawatt	MW
Messenger Wire	MSW
Metal Clad Cable	MC
Manhole Communications	MHC
Manhole Electrical	MHE
Main Breaker	MB

Mid-Point Anchor	MPA
Mid-Point Tie Wire	MPTW
Mile post	MP
Milli	m
Milliamperes	mA
Mineral Insulated	MI
Miniature Circuit Breaker	MCB
Minimum	MIN
Minimum Circuit Ampacity	MCA
Ministry of the Environment	MOE
Ministry of Transportation	MTO
Modified Transverse Mercator	MTM
Mop Sink	MS
Minisub (600V-208 V/120 V Transformer c/w Panelboard)	MS
Modified	MOD
Monitor and Control	M/C
Monitor Module (Fire Alarm/ Detection)	MM
Monitoring Console	MTRC
Motion/Vibration Switch	MVS
Motor Circuit Protection	MCP
Motor Control Center	MCC
Motor Starter	MST
Motorized Damper	MD
Motorized Damper Actuator	MDA
Molded Case Circuit Breaker	MCCB
National Electrical Code	NEC
National Electrical Manufacturers Association	NEMA
National Fire Protection Association	NFPA
National Inspection Council for Electrical Installation Contracting	NICEIC
National Pipe Thread	NPT
National Research Council	NRC

Negative Feeder	NF
Neutral	N
Network	NET
Network Cabinets	NETC
Network Operations Centre	NOC
Network Server	NS
Night Light	NL
Noise Criteria or Normally Closed	Ncri
Nominal	NOM
Non-Freeze Hose Bib	NFHB
Non-Potable Water	NPW
Normally Closed	NC
Normally Open	NO
Not to Scale	NTS
Number	#
Outside Building (Bunker, Kiosk, etc.)	OB
Occupational Health and Safety Act	OHSA
Occupancy Switch	OS
Ohms	Ω
On Center	OC
Ontario Building Code	OBC
Ontario Provincial Standard Drawing	OPSD
Ontario Electrical Safety Code	OESC
Open Drip Proof	ODP
Operating Current (Fuse or Circuit Breaker)	loc
Out of Running	OOR
Outlet Velocity	OV
Outside Air	OA
Outside Air Intake	OAI
Outside Buildings (Bunkers, Bungalows, sheds, Kiosk etc...)	OB
Outside Diameter	OD

Overhead lines	OHL
Overall Cable Diameter	De
Overhead	OH
Overhead Contact Line zone	OCLZ
Overhead Contact System	OCS
Overhead Conductor System	OHCS
Overhead wiring	OHW
Overlap	O/LAP
PA Speaker Unit	PSU
Packaged HVAC Unit	PHU
Pan Tilt Zoom	PTZ
Panel (Panel ID)	PNL
PA & Intercom Systems	PA
Panic Button	PAB
Paralleling Station	PS
Parking Garage	PG
Parking Structure	PStr
Parking Systems	PARK
Passenger Pick up and Drop off	PPUDO
Passenger Station / Station	STN
Passive Infrared Detector	PIR
Patch Cable	PPC
Patch Panel	PX
Pantograph	Panto
Phase	PH
Phase angle degrees	0 to 360°
Phase voltage	Uo
Photocell	PC
Photovoltaic Power Source	PV
Pit	PIT
Platform	PFM
Point of intersection of the Turnout	PITO

Point of Switch	P.S
Pole	PL
Pole Mounted Breaker	PMB
Pole Mounted Fused Switch	PMFS
Pole Mounted Switch	PMS
Polyvinyl Chloride	PVC
portal / Gantries	Gant
Potential Difference	p.d.
Potential Transformer	PT
Pound	LB
Pounds per Cubic Foot	PCF
Pounds Per Square Foot	PSF
Pounds per Square Inch	PSI
Pounds per Square Inch - Absolute	PSIA
Pounds per Square Inch - Differential	PSID
Pounds per Square Inch - Gauge	PSIG
Power	PWR
Power Distribution Panel	PP
Power Factor (Sinusoidal Systems)	Cos ϕ
Power House	POWRH
Pressure Drop	PD
Pressure Reducing Valve	PRV
Pressure Switch/Sensor	PS
Presto Rack	FARE
Preventive Maintenance Bay	LPMB
Printed Circuit Board Card	PCB Card
Programmable Logic Controller	PLC
Prospective Short-Circuit Current	PSC
Protective Extra-Low Voltage	PELV
Protective multiple bonding/grounding	PME
Public Address System	PA
Public Telephone (Bell)	BT

Punch Down Block	PDB
Pull Box	PB
Push Button	PUB
Push Button Station	PBS
Quantity	QTY
Rack	RK
Radio Frequency	RF
Radio Frequency Interference	RFI
Radio Line Amplifier	RFLA
Radio System	RS
Radius	R
Railway Safety Act	RSA
Reactance	X
Rectifier	RECT
Rectifier Transformer	RT
Reinforcement	REINF
Relative Humidity	RH
Relief	RLF
Remote Terminal Unit	RTU
Remote Test Station	RTS
Required	REQ
Residual Current Circuit Breaker	RCCB
Residual Current Device	RCD
Resistance (Electrical)	Ohms or Ω
Resistance of The Human Body	R _p
Resistance Temperature Detector	RTD
Return	RET
Return Air	RA
Return Cable	RC
Revolutions per Minute	RPM
Rigid Galvanized Steel	RGS
Rigid Galvanized Steel Conduit	RGSC

Right of Way	ROW
Rigid Metal Conduit	RMC
Rigid Non-Metallic Conduit	RNC
Rack	RK
Roof	RoF
Roof Drain	RD
Roof Top Unit	RfTU
Room	RM
Root Mean Squared	RMS
Running Load Amps	RLA
Router, Multiplexer	RT
Sanitary Drain	SAN
Sanitary Pump	SAN-P
Sanitary Vent	SAN-Vent
Saturated Condensing Temperature	SCT
Station Building	SB
SCADA Master Station	SMS
Screen	SCR
Seconds (time)	s
Section Breaks/Section Insulator	SB
Security Systems	S
Security Cabinet	SC
Security System	SMS -
Sensible	SEN
Sensible Heat Capacity	SHC
Separated extra-low voltage	SELV
Server	SRVR
Shed	SHED
Sheet Metal and Air Conditioning Contractors National Association	SMACNA
Shelter Waiting Area	SHLTR
Shunt Trip	ST

Silicon Control Rectifiers	SCR
Single Occupant Vehicle	SOV
Signal	SGNL
Signal Charger	SC -
Signal Lights	SL -
Signal System	SI -
Signalling	S
Single Mode	SIM
Smoke Damper	SMDR
Smoke Detector	SD
Smoke Exhaust	SE
Sound Transmission Class	STC
Spare	SPR
Spare Breaker	SPBR
Spare Cable	SCAB
Splitter	SPL
Square Feet	SqF
Stainless Steel	SS
Standards	STD
Standpipe	STP
Static Pressure	SP
Station	ST
Station Control Computer	SCC
Station Fare Transaction Processor	SFTP
Station Point of Sale	SPOS
Static Wire	STW
Station Distance	STA
Storm Drain	STM-D
Storm Pump	STM-P
Sub Grade Floors (Includes basements and below grade areas)	B1 to-B99
Substation	SubS

Sub Electrical Rooms	SEL
Sump Drainage	SUD
Supervisory Control and Data Acquisition System	SCADA
Supply	SUP
Supply Air	SA
Supply Air Temperature	SAT
Supply Fan	SF
Surge Protection Device	SPD
Suspension Insulator / Phase Break	SI -PB
Switch	SW
Switch Clearing Device	SCD
Switch Clearing Device Fan	SFCD -
Switch Machine	SM -
Switching Station	SWS
Symbol for Electric Current	I
Symbol for Voltage (Alternative For V)	U
Symmetrical	SYM
Tabulated Current	It
Tangent Curve	TC
Technical Standards and Safety Authority	TSSA
Telecommunications Grounding Busbar	TGB
Telecommunications Room (Any other space designated as a communications room which is not the primary.)	TR
Telephone	TEL
Telephone Outlet	T
Telephone Cabinet	TELC
Telephone Jack	TJ
Temperature	TEMP
Temperature Switch/Thermostat	TS
Terminal Block	TB
Test Point (Test Block)	TP/B
Total Resistance of The Bonding/Ground Electrode	Ra

Thermal Insulation Correction Factor	Ci
Thermal Magnetic Circuit Breaker	TMCB
Thermocouple	TC
Thermostat	Therm
Thermostat	TSTAT
Thousand Circular Mils	KCMIL
Time	t
Ticket Vending Machine	TVM
Toronto Transit Commission	TTC
To Be Determined	TBD
Top of	T/
Top of Rail	TOR
Total Static Pressure	TSP
Totally Enclosed Fan Cooled	TEFC
Track Circuit	TCCT
Track Circuits 10	#10 EPR
Track/ Rail	T/R
Tracks	TRKS
Traction Power Facility	TPF
Traction Power Substation	TPS
Traction Wayside Power Control Cabinet	TWPC
Transceiver	TCVR
Transformer	XFMR
Transient Voltage Surge Suppression	TVSS
Transmission Control Protocol/ Internet Protocol	TCP/IP
Transmission Backbone System	TBS
Trap Primer Distribution	TP
CCTV or TV Systems	TV
Tunnels	TNL
Typical	TYP
Under Ground	UG
Undercut (Door)	UC

Canadian Underwriters Laboratory	ULc
Uninterruptible Power Supply	UPS
UPS Power Distribution Panel	PPU
Union Pearson Express	UPE
Unit Heater	UH
Universal Serial Bus	USB
Urinal	UR
Valve - Circuit Balancing Valve	CBV
Valve - Drain	DV
Valve - Return	RV
Valve - Supply	SV
Variable Air Volume	VAV
Variable Frequency Drive	VFD
Velocity	VEL
Ventilation Hood	VH
Visual Comfort Probability	VCP
Volatile Organic Compound	VOC
Vertical	VERT
Vibration Switch	VS
Visual Message Sign	VMS
Volt - unit of EMF or Potential difference/drop.	V
Voltage Limiting Device	VLD
Voltage Transformer	VT
Volt-Ampere	VA
Volume Attenuator	VATT
Volume Damper	VD
Water Column	WCol
Water Closet	WC
Water Gauge	WG
Water Heater	WH
Water Main	WMn
Water Meter	WM

Water Pressure Drop	WPD
Water Temperature Difference	WTD
Watts (Power)	W
Wayside Panel Left Side	WSPLS
Wayside Panel Right Side	WSPRS
Wayside Power Cabinet	WSPC
Weatherproof	WP
Wet Bulb Temperature	WB
Wet Sprinkler	SPR-WET
Wheel Maintenance House	LWR
Wheeled Mobility Aids	WMA
Wireless Access Points	WAP
Width	Wid
Working Point	WPT

9. EXECUTION

9.1. SUBMITTALS

- 9.1.1. Shop drawings shall be submitted in accordance with the contract documents. Shop drawings and other submittals shall indicate the following:
- Fasteners, colour of background, dimensions, thickness, finish colour of identification letters per method and application; and
 - Composite identification label and fastener details.

9.2. APPROVALS

- 9.2.1. Identification is subject to prior approval of Metrolinx.

9.3. PRODUCTS

- 9.3.1. Wire and Cable Markers shall include the following:
- Heat shrink sleeves, blank;
 - Clear plastic tape wrap-on strips with white writing section;
 - Wrap-on strips, pre-numbered; and

- d) Slip-on identification bead markers or sleeves, blank or pre-numbered.

9.3.2. Wrap-around colour identification markers shall include the following:

- a) Coloured metallic cable ties; and
- b) Coloured aluminum cable ties of:
 - 1) Width 8 mm;
 - 2) Lengths 140 mm, 201 mm, 362 mm to suit cable or conduit diameters of 25 mm, 51 mm, 102 mm; and
 - 3) Colours: blue, green, red yellow, black, clear aluminum.

9.3.3. Coloured Hook and Loop non-metallic cable ties shall have:

- a) Coloured non-metallic cable ties, adjustable and reusable, hook-and-loop material, -18 °C to 104 °C;
- b) Widths 8.4 mm, 13 mm, 19 mm;
- c) Lengths 150 mm, 300 mm, 457 mm; and
- d) Colours: black, red, orange, yellow, green, blue, grey, white

9.3.4. Electrical colour coding tape shall have:

- a) PVC backing, 0.178 mm thick indoor outdoor suitable, pressure sensitive rubber adhesive, coloured, fade resistant, abrasion and weather resistant, to CSA C22.2 No 197-M:
 - 1) 1) Widths: 13 mm, 19 mm
- b) Colours: black, brown, red, orange yellow, green, blue, grey, white, violet

9.4. COLOURS

9.4.1. Product colours are indicated herein. The colours can be provided by the following means:

- a) Paint:
 - 1) Refer to specification section on painting, otherwise treat as shop primed ferrous metal - alkyd finish:
 - i) Coat alkyd, paint code 48, gloss enamel; and

- ii) Paint code 48 - interior alkyd gloss enamel conforming to CAN/CGSB-1.60-M.
- b) Bands;
- c) Tape;
- d) Tags; and
- e) Signs

9.5. LABELS AND NAMEPLATES

9.5.1. Labels shall comply with the following requirements:

- a) Use products that comply with TIA-606B and CSA-T528;
- b) Prepare labels by use machine printing, avoid use of handwritten labels;
- c) Self-adhesive, self-laminating material, with engrave area;
- d) Minimum two times full wrap-around cable;
- e) Labels to suit selected faceplate;
- f) Grounding bus bars shall be self-adhesive, white engraved areas, minimum size 25 x 50 mm, and characters minimum height 12 mm;
- g) Patch panels shall be self-adhesive, white engraved areas to suit selected patch panel or termination strip;
- h) Patch panels shall be screwed in place white engraved to suit poor conditions complete with self- adhesive; and
- i) Rack, mcc and cabinets etc., shall be self-adhesive, white engraved areas, minimum size 50 x 75 mm and characters minimum height 12 mm.

9.5.2. Nameplates and labels shall comply with the following requirements:

- a) Identify each cable tray in accordance with cable tray schedule;
- b) Characters are to be black, 75 mm high and painted on side walls using stencils;
- c) Space cable tray identification markings a maximum of 10 meter along cable tray runs and a minimum of once in every section and in every room, in a visible location;

- d) Identify cable trays carrying voltages above 600 volts in addition to the above, as follows: characters are to be white, 75 mm high, on a red background and read "danger - high voltage"; and
- e) Space high voltage identification at a maximum of 3 m intervals and at least once in every section and in every room or area, and on both sides of trays where applicable.

9.5.3. Conduits shall comply with the following requirements:

- a) Colour code conduits and metallic sheathed cables with permanent plastic tape or paint strip at points where conduit or cable enters wall, ceiling, or floor and at 15-meter intervals;
- b) Number conduits within 150 mm of a box, device or equipment from which it originates;
- c) Identify embedded conduit with conduit tags, securely affixed to the surface of the concrete adjacent to the box, device or equipment from which it originates. Arrange conduit tags to clearly identify the conduit number and its appropriate conduit. Secure conduit tags to the substrate with a minimum of two stainless steel fasteners. Tags for embedded conduit within manholes and handholes are to be located on the vertical concrete face above the location of the conduit;
- d) Identify exposed conduit with conduit tags;
- e) Arrange the numbering on the conduit tags to prevent numbers from being obscured by adjacent conduit;
- f) Identify each end of the conduit with a tag, 150 mm from where it enters a panel, box or equipment; and
- g) Colours: prime 25 mm wide; auxiliary 19 mm.

9.5.4. Identification of wiring shall comply with the following requirements:

- a) Identify No 8 AWG wiring & smaller using wire identification methods;
- b) Types or print on blank wire identification materials using indelible black ink;
- c) Identify wiring at all pull boxes, junction boxes, and outlet boxes for all systems;
- d) Identify each conductor as layout in section Labelling Nomenclature include in labelling panel & circuit, terminal, terminal numbers, system number scheme and polarization, as applicable;
- e) Wire markers:

- 1) Locations: Each conductor in a panel board, pull boxes, outlet and junction boxes, patch panel, rack and each connection; and
- 2) Wire Identification Materials, use one of the following:
 - i) Heat shrink sleeves, blank;
 - ii) Wrap on strips, pre numbered; or
 - iii) Slip on identification bead markers or sleeves, blank or pre numbered.
- f) As built drawings to match wire ID;
- g) Power and lighting circuits: branch circuit / feeder number indicated on drawings;
- h) Control circuits: Control wire number indicated on schematic and interconnection diagrams on drawings & Shop Drawings; and
- i) Wiring tables and riser diagram.

9.6. INSTALLATION PROCEDURES

- 9.6.1. Verify the condition and dimensions of previously installed Work upon which this Section depends and report any defects to Metrolinx. Commencement of Work means acceptance of existing conditions. Installation shall be as follows:
 - a) Install electrical identification in accordance with manufacturer's written instructions;
 - b) Install nameplate and label parallel to equipment lines after degreasing and cleaning surfaces to receive;
 - c) Secure nameplate to equipment front using adhesive, and screws;
 - d) Secure nameplate to inside surface of door on panel board that is recessed in finished locations;
 - e) Identify conduit using field painting to painting section;
 - f) Paint coloured band on each conduit longer than 2 m (6 feet);
 - g) Paint bands 6 m (20 feet) on centre; and
 - h) Colour: refer to table "colour identification of equipment" including conduits, boxes, splitters and panels.

10. SYSTEM SPECIAL REQUIREMENTS

10.1. SIGNALLING

- 10.1.1. In accordance with CSA standard C22.1, identify power wiring with wire markers, on both ends of phase conductors of feeders and branch circuit wiring.
- 10.1.2. Identify control wiring with wire markers, numbered in accordance to wiring interconnection lists, schematic diagrams and schedules which if not provided shall be created for the as builds required for the project.
- 10.1.3. Use colour coded wires in power and communication cables, matched throughout the systems.
- 10.1.4. Identify individual wires with wire markers applied at both ends of the wire.
- 10.1.5. Circuiting designation is to include panel designation, circuit number and wiring at devices, including terminal blocks and junction points.
- 10.1.6. Provide a wire identification system consistent with the schematics existing for created for the as built submission.
- 10.1.7. Place identification labels within 10 mm of terminating points in visible locations. Maintain phase sequence and colour coding throughout the work.
- 10.1.8. Signal Codes of Practice (SCPs), specifically, SCP 1004 Standard Signal Wire and Cable shall be followed.
- 10.1.9. Where wording of identifications is not specified in Contract Documents, the Contractor shall obtain the required wording from Metrolinx.
- 10.1.10. For dedicated signalling Products, Subsystems and Systems, the Contractor shall provide an identification system utilising the following Geographical Divisions:
- 10.1.11. Geographical designations shall follow the names of the interlocking, storage yard and buildings as XX - XXXXX.
- 10.1.12. Signalling circuits special identification are as follows:
 - a) Apply tags or sleeves to wires immediately adjacent to terminals or binding posts. Place tags so they can be read directly and will not touch work below the terminals;
 - b) Make temporary tags of an insulating material;
 - c) Identify pull boxes, terminal cabinets and junction boxes enclosing cables or connections with nameplates. Arrange nameplate to clearly identify the pullbox number;

- d) Paint pullboxes, junction boxes and electrical panels (containing modules) associated with fire alarm/detection system ANSI safety red; and
- e) For buried incoming services, install “buried-cable” markers on buildings where buried service enters.

10.1.13. Raceway system identification

- a) Conduit: All conduits 53mm (2”) and above shall be listed on a conduit schedule.
- b) Conduit: signalling conduits, shall be listed on conduit schedule and identified as CI - SI - 001 where:
 - 1) CI - geographical division. For Interlockings, use the applicable designation. Confirm geographical divisions with Metrolinx;
 - 2) SI - function; and
 - 3) 001 - sequential number.
- c) Function of conduit shall be identified as follows, in Table 14:

Table 14: Conduit Function Identifiers

Identifier	Equipment Description
SI	Signal System
SL	Signal Lights
SC	Signal Charger
SW	Switch Machine
TC	Track Circuit
CC	Code System Charger

- d) Pullboxes and junction boxes: pullboxes and junction boxes, other than those for lighting and receptacle circuits, shall be listed on electrical box schedule.
- e) Pullboxes and junction boxes used for signalling circuits shall be listed on a schedule and identified as SI - S - 001, where:
 - 1) SI - geographical division, confirm geographical division with Metrolinx;
 - 2) S - signalling; and
 - 3) 001 - sequential number.

- f) Cable trays used for signalling circuits shall be identified as BY - S - 001, where:
 - 1) BY - geographical division, confirm geographical division with Metrolinx;
 - 2) S - signalling; and
 - 3) 001 - sequential number.

10.1.14. Signal cable system identification

- a) Cable whose origin and destination are within the same geographical division as DY - 6SW1 / WSPLS1 - P 01 shall be identified where:
 - 1) DY - geographical division. For Interlockings use the applicable designation per Paragraph 9.1.11 above. Confirm geographical divisions with Metrolinx;
 - 2) 6SW1 - Product identifier with sequential number for cable's origin;
 - 3) 6WSPLS1 - Product identifier with sequential number for cable's destination;
 - 4) S - signalling cable; and
 - 5) 01 - Sequential number.
- b) Cable whose origin is in one (1) geographical division and destination in another geographical division as BI - BGW01 - TB01 / EI - BGW02 - TB03 - S 01 shall be identified where:
 - 1) BI - BGW01 - geographical division number for cable's origin;
 - 2) TB01 - Product identifier with sequential number for cable's origin;
 - 3) EI - BGW02 - geographical division number for cable's destination;
 - 4) TB03 - Product identifier with sequential number for cable's destination;
 - 5) S - cable category; and
 - 6) 01 - Sequential number.
- c) Signalling circuits special identification requirement shall be as follows:
 - 1) General: The Contractor shall permanently identify both ends of each wire that terminate on instrument racks terminal boards, instrument cases or junction boxes with tag or identifying sleeve. In general, use identifying sleeves for instrument rack terminations and tags for terminal board, wayside case, and junction box wire terminations;

- 2) External wires terminated on A.A.R. Terminal Posts: The Contractor shall Label wiring with transit flat tags listing rack or case number and terminal number, circuit description, and location and terminal of the other end of the wire. Example in Table 15:

Table 15: Example of Signalling Circuits Identification

Terminal block termination point	D46
Circuit description	18H
Wire destination and termination point	E54
Terminal row and number	A21
Circuit description	18H
Wire destination location and terminal number	Case 42 C6

- 3) Non-Vital relay wiring: The Contractor shall label wire with sleeve listing relay contact number; and
- 4) Vital relay wiring: The Contractor shall label wires with sleeves listing the relay location on the rack, relay contact point (F=Front, H=Heel, B=Back), circuit description, destination of the other end of the wire, and termination point at other end. Example in Table 16:

Table 16: Example of Vital Relay Wiring Identification

Instrument (Relay) rack and contact	3E8-3F
Circuit description	18H
Wire destination and termination point	2B4-5B

- d) Wiring to solderless screw-clamp terminal blocks: The Contractor shall label wires with sleeves listing the termination point on the terminal block, circuit description, destination of the other end of the wire and termination point at the other end.
- e) Cables: The Contractor shall label cables with wrap-around tags listing the cable type, with number of conductors and routing. Example in Table 17:

Table 17: Example of Cable Labelling

Cable type	8C
Cable routing	BGW02

10.1.15. Electrical equipment shall be identified by the Contractor as follows:

- a) Electrical equipment as SI - LCP -1 where:
 - 1) SI - geographical division, confirm geographical division with Metrolinx;
 - 2) LCP - Product identifier; and
 - 3) 1 - Sequential number.
- b) Product identifier shall be as follows, in Table 18:

Table 18: Electrical Equipment Product Identifiers

Identifier	Equipment Description
CTC	Cable Termination Cabinet
GR	Grounding
JB	Junction Box
R	Rack
LA	Lightning Arrestor
LCP	Local Control Panel
PB	Pull Box
SCD	Switch Clearing Device
TB	Terminal Block
TP	Test Point (Test Block)
CP	Control Panel
WSPLS	Wayside Panel Left Side
WSPRS	Wayside Panel Right Side

10.1.16. Signalling Schematic Device/ Wiring Identification

- a) Device and wiring identification on schematics shall be in accordance with Figure 1.

Figure 1: Device and Wiring Identification

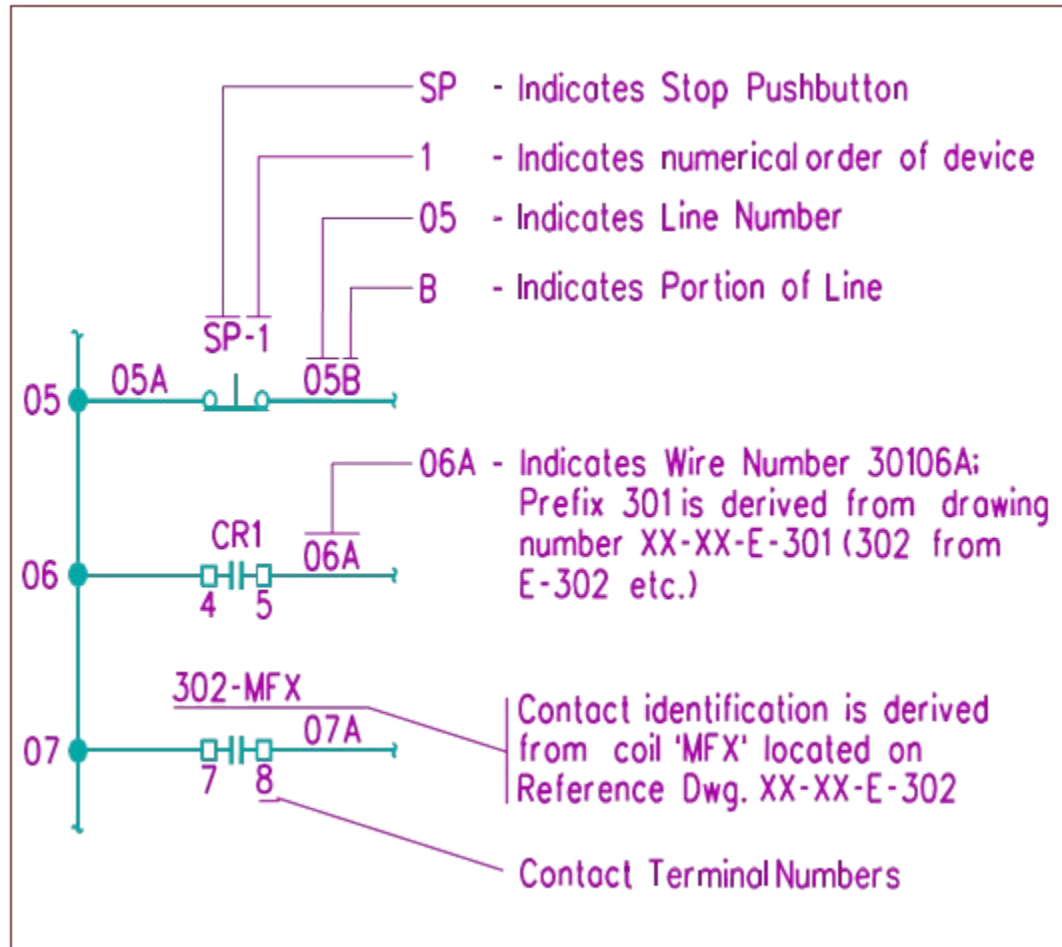

11. EXAMPLES

Example 1

A power conduit is run from the UPS unit in the main electrical room, which is found in room 101 within the station building to the communication room distribution panel (room 102)

+(MEL_SB).(UPS-01):(1,3,5)=(EL)-(208)-(001)+(MC_SB102).(PPU-01):(MB)

Site Source: MEL - Main Electrical Room

Location on Site/Room Number: SB - Station Building

Panel/Pole/Box/Splitter/Equipment: UPS-01

Circuit Number: 1,3,5

Conduit Function: EL - electrical power

Conduit Voltage: 208-208VAC

Conduit Number: 001

Site Destination: MC - Main Communications Room

Location on Site/Room Number: SB102 - Station Building Room 102

Panel/Pole/Box/Splitter/Equipment: PPU-01

Circuit Number: MB - Main Breaker

Example 2

Power cables are run in a conduit from the UPS unit in the main electrical room, which is found in room 101 within the station building to the communication room distribution panel (room 102)

+(MEL_SB).(UPS-01):(1)=(EL)-(208)-(001)+(MC_SB102).(PPU-01):(MB)
+(MEL_SB).(UPS-01):(3)=(EL)-(208)-(002)+(MC_SB102).(PPU-01):(MB)
+(MEL_SB).(UPS-01):(5)=(EL)-(208)-(003)+(MC_SB102).(PPU-01):(MB)
+(MEL_SB).(UPS-01):(N)=(EL)-(208)-(004)+(MC_SB102).(PPU-01):(MB)
+(MEL_SB).(UPS-01):(GND)=(EL)-(208)-(005)+(MC_SB102).(PPU-01):(MB)
+(MEL_SB).(UPS-01):(SPR)=(EL)-(208)-(006)+(MC_SB102).(PPU-01):(MB)

Site Source: MEL - Main Electrical Room

Location on Site/Room Number: SB - Station Building

Panel/Pole/Box/Splitter/Equipment: UPS-01

Circuit Number: 1,3,5, N-Neutral, GND-Ground, SPR-Spare

Conduit Function: EL - electrical power

Conduit Voltage: 208 - 208VAC

Conduit Number: 001-006

Site Destination: MC - Main Communications Room

Location on Site/Room Number: SB102 - Station Building Room 102

Panel/Pole/Box/Splitter/Equipment: PPU-01

Circuit Number: MB - Main Breaker

Example 3

A power junction box JB001, located in the tunnel 1 is fed from the lighting panel in the sub electrical room, which is found in room 101 within the station building to the fixture LS-001 located in shelter waiting area 01 located on platform 3, then connecting to another fixture LS-002 from the same junction box

+(SEL_SB201).(DP-01+MEL_SB101/JB001_NT):(4)=(EL)-(208)-(JB002)+(PL3_SHLTR01).(LS-001):(M)
+(SEL_SB201).(DP-01+MEL_SB101/JB001_NT):(4)=(EL)-(208)-(JB003)+(PL3_SHLTR02).(LS-002):(M)

Site source: SEL - Sub Electrical Room

Location on site/Room number: SB201 - Station Building Room 201

Panel/Pole/Box/Splitter/Equipment: DP-01

Location on site/Room number: MEL - Main Electrical Room/SB101 - Station Building Room 101

Location on site/Room number: TNL1 - Tunnel 1

Equipment Function: EL - electrical power

Equipment Voltage: 208 - 208VAC

Site Destination: JB002 - junction box 002, JB003 - junction box 0003

Location on Site/Room Number: PL3 - platform 3, SHLTR01 - Shelter Waiting Area 01, SHLTR02 - Shelter Waiting Area 02

Panel/Pole/Box/Splitter/Equipment: LS-001 - Light Fixture 001, LS-002 - Light Fixture 002

Example 4

A 120/208V distribution panel located within the station building in the main electrical room 201 will look like this:
(MEL_SB201)
(2DP19)

Where:

Site Source: MEL - Main Electrical Room

Location on site/Room Number: SB201 - Station Building Room 201

Panel Voltage: 2 - 120/208

Panel Type: DP - Distribution Panel

Sequential Number: 19

Example 5

A 120/208V 200A 3ph, 4 wire distribution panel with interrupting rating of 18kA located within the station building in the main electrical room 201 will look like this:

(MEL_SB201)

(2DP19)

120/208, 200A, 3, 4, 18kA

Fed From: (MEL_SB201)(2DPA1):(1,3,5)

JB001

Destination Information: N/A

Meter Address: 192.184.0.1

Voltage, Ampacity, Phase, Pole, Interrupting Rating (if applicable)

Fed From: (equipment name): (circuit number)

Nearest Junction Box/Hand Hole unique name (if applicable)

Destination Information: (if applicable)

Meter Address: (if applicable)

Example 6

A lighting pole on platform 1 which contains 2 lighting fixtures and 2 PA speakers, is fed from (MEL_SB201)(2DP19), has 2 circuits.

(Plat1)

(LPL1)

120,15A, 1, 1, 10Ka

Fed From: (MEL_SB201)(2DP19):(2,4)

(MC_SB202)(AMP01A):(1)

(MC_SB202)(AMP01B):(1)

HHE-01, HHC-01

Destination Information: LP-01, LP-02, PA-01, PB-01

12. SIGNALLING ELECTRICAL EQUIPMENT

12.1.1. For buried incoming services, install "Buried-Cable" markers on buildings where buried service enters.

13. ELECTRIFICATION REQUIREMENTS

13.1.1. Electrification requirements to be determined.

14. QUALITY ASSURANCE

14.1.1. Quality assurance submittals to be submitted in accordance with section on Submittal Procedures.

-End of Document-