

GUARD RAIL ASSEMBLIES

NOTES

- TURNOUT TO BE INSTALLED AND MAINTAINED IN ACCORDING WITH THE LATEST ISSUE OF:
 RM .3500 TURNOUTS
 RM .3502 POWER, SPRING AND INSTALLED SWITCH
 RM .3506 SWITCH STAND, SWITCH LAMPS AND TARGETS, WHERE APPLICABLE
- WHEN REFERRING TO POWER OPERATED TURNOUTS, DRAWING NUMBER MUST BE STATED AS A, B,C OR D:
 A-RIGHT HAND TURNOUT P.O. MACHINE ON RIGHT
 B-RIGHT HAND TURNOUT P.O. MACHINE ON LEFT
 C-LEFT HAND TURNOUT P.O. MACHINE ON RIGHT
 D-LEFT HAND TURNOUT P.O. MACHINE ON LEFT
- FOR THE VARIOUS STANDARD TURNOUT COMBINATIONS SEE INDEX SHEET GTS-0
- TURNOUT GEOMETRY, FOR TABLES OF DIMENSIONS AND OFFSETS SEE GTS-1

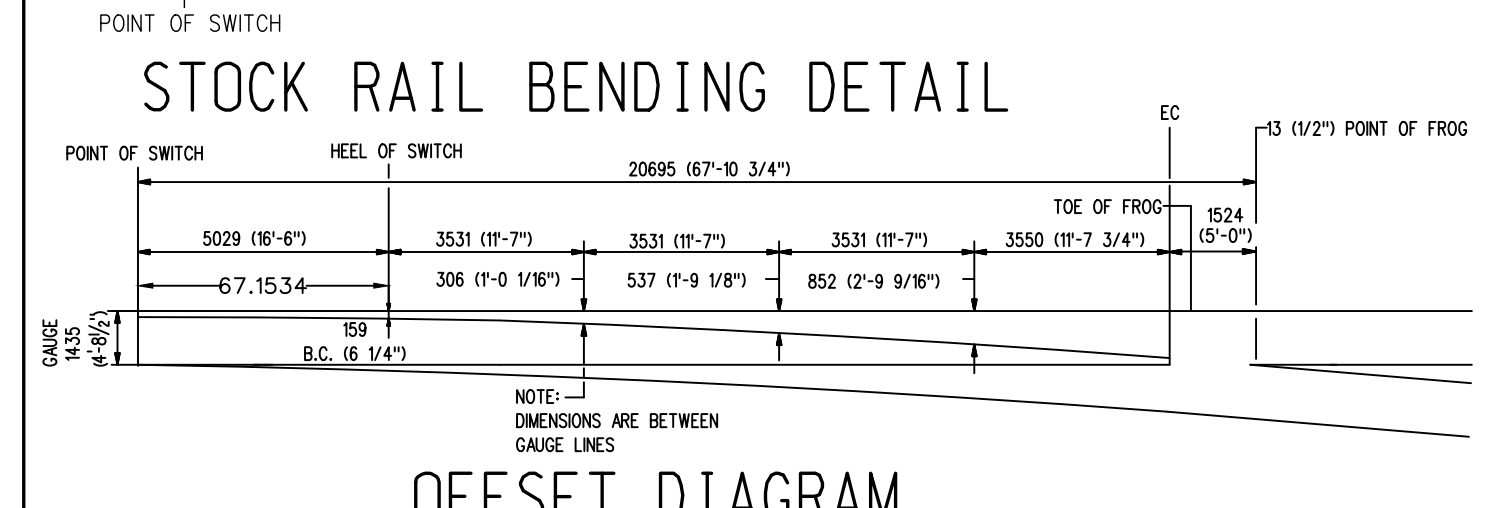
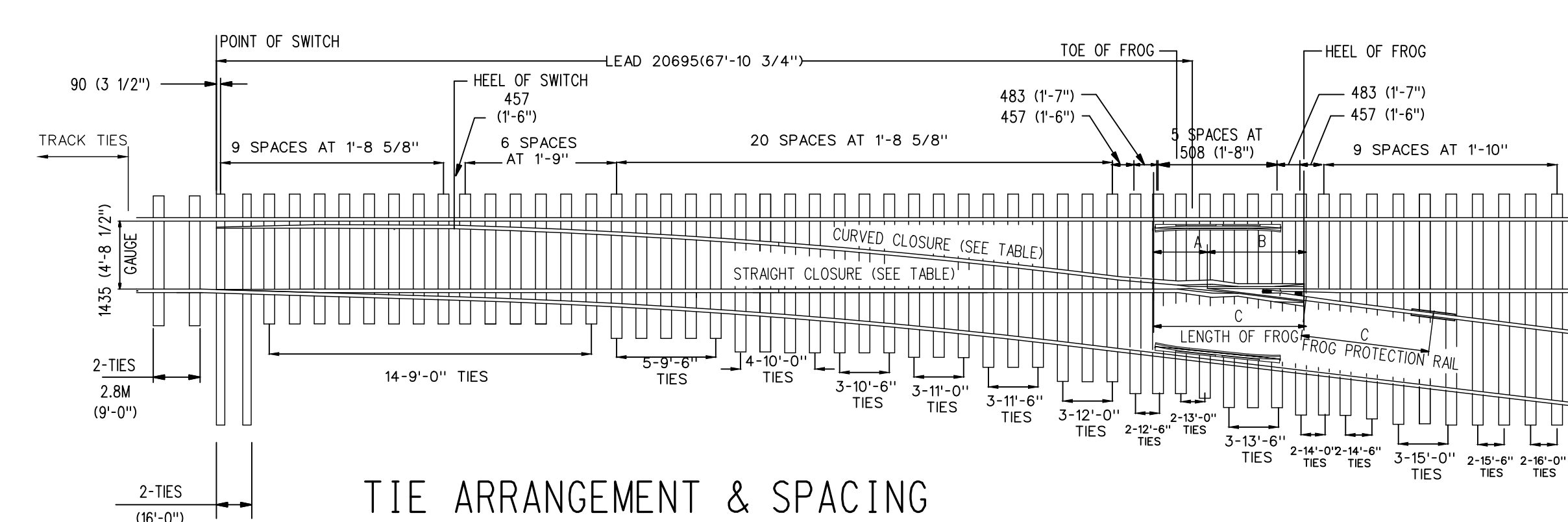

TIE ARRANGEMENT & SPACING

TURNOUT DATA:

FROG NO -----8
 LENGTH OF SW.P.T.-----5029(16'-6")
 HEEL SPREAD-----159(6 1/4")
 LEAD-----20695(67'-10 3/4")
 PS TO H.F.-----23133(75'-10 3/4")

14143(46'-4 3/4") STRAIGHT CLOSURE LENGTH
 MADE UP BY A 14143(46'-4 3/4") RAIL OR:
 A 10058(33') AND 4085(13'-4 3/4") RAIL
 A 9144(30') AND 4999(16'-4 3/4") RAIL
 14205(46'-7 1/4") CURVE CLOSURE LENGTH
 MADE UP BY A 14205(46'-7 1/4") RAIL OR:
 A 10058(33') AND 4147(13'-7 1/4") RAIL
 A 9144(30') AND 5061(16'-7 1/4") RAIL

METRIC CONVERSION: 1 inch=25.4mm, 1 foot=304.8mm

1	18/07/27	ADDED IMPERIAL TO METRIC CONVERSION NOTE	
No.	Date	Revision	By Approved
Standard		NO. 8 TURNOUT-16'6" POINTS POWER OPERATED R.B.M. FROG 100LB. A.R.A.A. RAIL	
Drawn	Checked	Approved	Management
MG	GGG		
Date		Plan	Rev
DEC 15, 2017		Number	GTS-0048 1
REFERENCE: TS-48 A/D			Sheet 1 OF 1



BILL OF MATERIALS FOR GTS-0048

ITEM	DESCRIPTION	STANDARD DRAWING	MARK NO.	QUANTITY			
				A	B	C	D
SWITCH PACK							
1	1st. GAUGE PLATE C/W INSULATION PLATE 100/132	GTS-0521	GP63/GP60	1	1	1	1
2	2nd. GAUGE PLATE C/W INSULATION PLATE 100/132	GTS-0521	GP67/GP61	1	-	-	-
	2nd. GAUGE PLATE C/W INSULATION PLATE 100/132	GTS-0521	GP65/GP64	-	1	-	-
	2nd. GAUGE PLATE C/W INSULATION PLATE 100/132	GTS-0521	GP64/GP62	-	-	1	-
	2nd. GAUGE PLATE C/W INSULATION PLATE 100/132	GTS-0521	GP61/GP69	-	-	-	1
3	3rd. GAUGE PLATE C/W INSULATION PLATE 100/132	GTS-0521	GP68/GP61	1	-	-	-
	3rd. GAUGE PLATE C/W INSULATION PLATE 100/132	GTS-0521	GP66/GP64	-	1	-	-
	3rd. GAUGE PLATE C/W INSULATION PLATE 100/132	GTS-0521	GP64/GP63	-	-	1	-
	3rd. GAUGE PLATE C/W INSULATION PLATE 100/132	GTS-0521	GP61/GP70	-	-	-	1
4	MILD STREET STRAP	GTS-0356C	356C	1	1	1	1
5	MILD STREET STRAP	GTS-0356D	356D	1	1	1	1
6	MILD STREET STRAP	GTS-0356A	356A	1	1	1	1
7				30	30	30	30
	DOUBLE SPRING WASHER - TYPE FE6	GTS-1310	-	30	30	30	30
8	SWITCH ROD	GTS-0344A	344A	1	1	1	1
9	SWITCH ROD	GTS-0344F	344F	1	1	1	1
10	RIGHT POINT RAIL	GTS-0307A	307A	1	1	1	1
11	LEFT POINT RAIL	GTS-0307B	307B	1	1	1	1
12	SWITCH PLATE	GTS-0508	SP300	6	6	6	6
13	SWITCH PLATE	GTS-0509	SP301	10	10	10	10
14	SWITCH PLATE	GTS-0504	SP123	2	2	2	2
15	SWITCH PLATE	GTS-0507	SP151	2	2	2	2
16	SWITCH PLATE	GTS-0507	SP152	2	2	2	2
17	SWITCH PLATE	GTS-0506	SP153	2	2	2	2
18	HOOK TWIN TIE PLATE	GTS-0503	LR27	8	8	8	8
19	HOOK TWIN TIE PLATE	GTS-0503	L27	8	8	8	8
20	HOOK TWIN TIE PLATE	GTS-0503	LR31	4	4	4	4
21	HOOK TWIN TIE PLATE	GTS-0503	L31	4	4	4	4
22	HEEL BLOCK (RIGHT HAND)	GTS-0358	16-6&22CP1-S	1	1	1	1
23	HEEL BLOCK (LEFT HAND)	GTS-0358	16-6&22CP2-S	1	1	1	1
24	BENT SPLICE BAR (4 HOLE) 100 LB. A.R.A. -A.	GTS-1204B	1204B	2	2	2	2
25	STRAIGHT SPLICE BAR (4 HOLE) 100 LB. A.R.A. -A.	GTS-1201	-	1	1	1	1
26	SPRING WASHER for 1" DIA. BOLT	GTS-1301	-	8	8	8	8
27	1" DIA. 8 NC OVAL NECK TRACK BOLT X 12" LG. C/W SQ. NUT	GTS-1319/9	-	8	8	8	8
28	PIPE THIMBLE 1" DIA. X 2-1/32" LONG	GTS-3548	B	2	2	2	2
29	ADJUSTABLE RAIL BRACE	GTS-0354	100M-7	12	12	12	12
30	7/8" DIA. - 9 UNC SQ. HD. BOLT X 3-3/4" LG.	GTS-1308/5	-	24	24	24	24
31	SPRING WASHER for 7/8" DIA. BOLT	GTS-1301	-	24	24	24	24
32	DOUBLE WASHER	GTS-0354	M-10	12	12	12	12
33	DOUBLE NUT	GTS-0354	M-9	12	12	12	12
34	PANDROL CLIP - PR 631A	GTS-1322	-	2	2	2	2
	FROG						
35	#6-100 LB. RAIL BOUND MANGANESE STEEL FROG	R11C - 164.1	-	1	1	1	1
	FROG PACK						
36	HOOK TWIN TIE PLATE	GTS-0503	L23	9	9	9	9
37	HOOK TWIN TIE PLATE	GTS-0503	LR27	2	2	2	2
38	HOOK TWIN TIE PLATE	GTS-0503	L27	5	5	5	5
39	HOOK TWIN TIE PLATE	GTS-0503	LR23J	2	2	2	2
40	HOOK TWIN TIE PLATE	GTS-0503	L23J	2	2	2	2
41	HOOK TWIN TIE PLATE	GTS-0503	LR27J	2	2	2	2
42	HOOK TWIN TIE PLATE	GTS-0503	L27J	2	2	2	2
43	STRAIGHT SPLICE BAR (4 HOLE) - 100 LB. A.R.A. -A.	GTS-1201	-	4	4	4	4
44	SPRING WASHER for 1" DIA. BOLT	GTS-1301	-	16	16	16	16
45	1" DIA. - 8 NC OVAL NECK TRACK BOLT X 5 - 5/8" LG. C/W SW. NUT	GTS-1319/1	-	16	16	16	16
	GUARD RAIL PACK						
46	FROG GUARD RAIL 11' - 0" LONG	GTS-1106	-	2	2	2	2
47	HOOK TWIN TIE PLATE	GTS-0503	L23	28	28	28	28
48	SPRING WASHER for 1-1/4" DIA. BOLT	GTS-1301	-	10	10	10	10
49	1-1/4" DIA. 7 UNC SQ. HD. BOLT X 9" LG. C/W SQ. NUT	GTS-1309/67	-	2	2	2	2
50	1-1/4" DIA. 7 UNC SQ. HD. BOLT X 9 - 1/2" LG. C/W SQ. NUT	GTS-1309/68	-	4	4	4	4
51	1-1/4" DIA. 7 UNC SQ. HD. BOLT X 10 - 1/2" LG. C/W SQ. NUT	GTS-1309/71	-	4	4	4	4
52	HEAD WASHER	GTS-0836L	836L	10	10	10	10
53	END CASTING-RIGHT HAND 100 LB. A.R.A. -A.	GTS-0846	CG2-S	2	2	2	2
54	END CASTING-LEFT HAND 100 LB. A.R.A. -A.	GTS-0846	CG3-S	2	2	2	2
55	TAIL WASHER (BEVELLED)	GTS-0836H	836H	8	8	8	8
56	TAIL WASHER (NOT BEVELLED)	GTS-0836M	836M	2	2	2	2
57	ADJUSTABLE BLOCK 100 LB. A.R.A.-A.	GTS-0846	CG1-S	4	4	4	4
	TURNOUT PACKAGES						
TURNOUT NUMBER	DESCRIPTION		QUANTITY PER TURNOUT				
GTS- 046A	FROG RBM NO. 8 - 100		1				
	SW-PK INS 16-6" PO NO. 8A-100 LBS.		1				
	GR-PK 100 11'-0"		1				
	FR-PK RBM 8-100		1				
GTS- 048B	FROG RBM NO. 8 - 100		1				
	SW-PK INS 16-6" PO NO. 8B-100 LBS.		1				
	GR-PK 100 11'-0"		1				
	FR-PK RBM 8-100		1				
GTS- 048C	FROG RBM NO. 8 - 100		1				
	SW-PK INS 16-6" PO NO. 8C-100 LBS.		1				
	GR-PK 100 11'-0"		1				
	FR-PK RBM 8-100		1				
GTS- 048D	FROG RBM NO. 8 - 100		1				
	SW-PK INS 16-6" PO NO. 8D-100 LBS.		1				
	GR-PK 100 11'-0"		1				
	FR-PK RBM 8-100		1				
ABBREVIATIONS							
SW - PK - SWITCH PAK			SGM - SELF GUARD MANGANESE				
FR - PK - FROG PAK			HO - HAND OPERATED				
GR - PK - GUARD RAIL PAK			RBM - RAIL BOUND MANGANESE				
INS - INSULATED			SO - SPRING OPERATED				
SAM - SAMSON							
NOTE:							
1 - For a new installation, necessary rail, bonded insulated joints, splice bars, bolts, washers, rail anchors, connecting rod, switch stand, target and reflectorized target kit may be required in addition to the materials listed above							
BILL OF SWITCH TIES FOR HAND AND SPRING OPERATION				BILL OF SWITCH FOR POWER OPERATION			
TIES 180 X 230 mm (7" X 9")				TIES 180 X 230 mm (7" X 9")			
LENGTH				LENGTH			
METRES	FEET/INCHES	NO. OF PIECES	METRES	FEET/INCHES	NO. OF PIECES	METRES	FEET/INCHES
2.8	9' - 0"	16	2.8	9' - 0"	14		
3.1	10' - 0"	9	3.1	10' - 0"	6		
3.4	11' - 0"	6	3.4	11' - 0"	4		
3.7	12' - 0"	8	3.7	12' - 0"	3		
4	13' - 0"	4	4	13' - 0"	4		
4.3	14' - 0"	5	4.3	14' - 0"	3		
4.6	15' - 0"	5	4.6	15' - 0"	3		
4.9	16' - 0"	4	4.9	16' - 0"	4		
TOTAL NUMBER OF TIES - 57			TOTAL NUMBER OF TIES - 41				