

GENERAL ARRANGEMENT
DRAWING NO. GTS-0251 A
RIGHT HAND TURNOUT

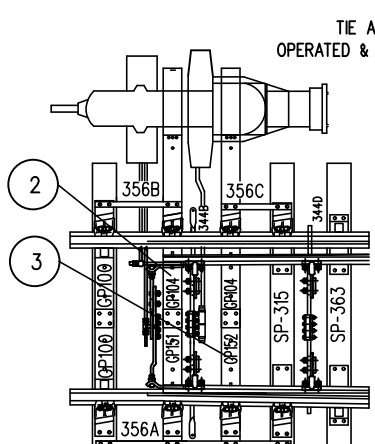

DRAWING NO. GTS-0251 B
RIGHT HAND TURNOUT
MACHINE MOUNTED ON LEFT

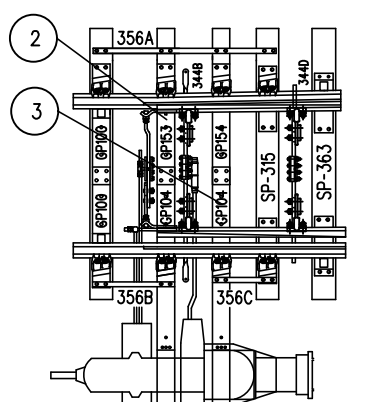

DRAWING NO. GTS-0251 C
LEFT HAND TURNOUT
MACHINE MOUNTED ON RIGHT

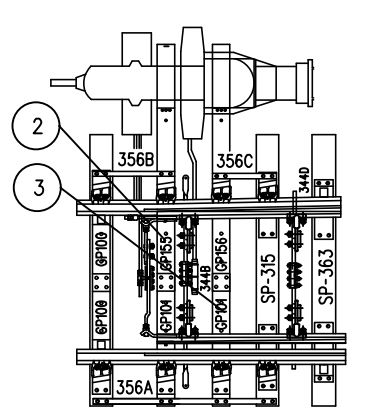

DRAWING NO. GTS-0251 D
LEFT HAND TURNOUT
MACHINE MOUNTED ON LEFT

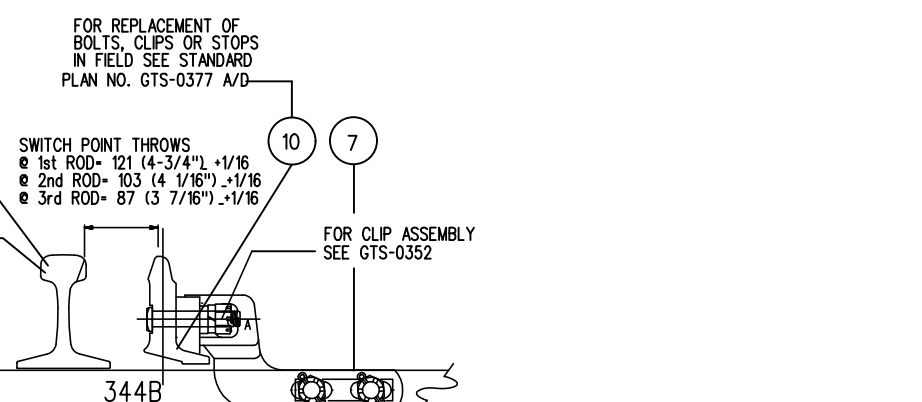

"MJS" CLIP ASSEMBLY

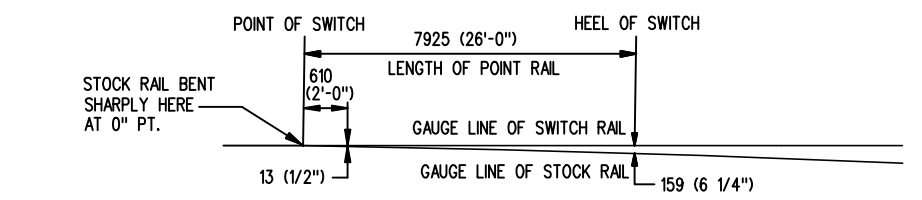

STOCK RAIL BENDING DETAIL

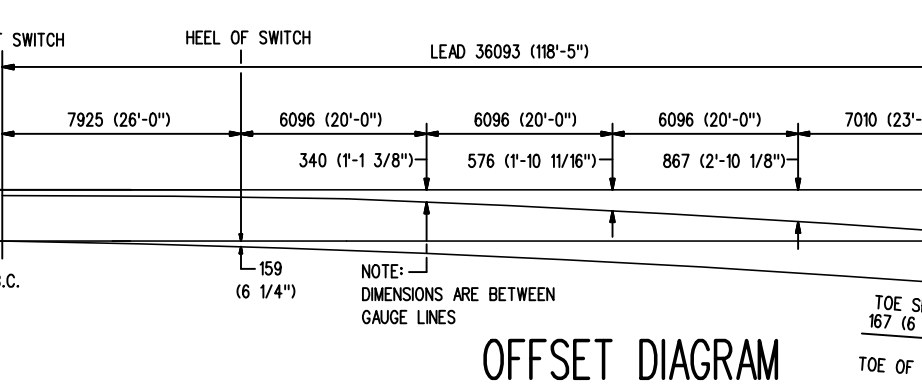

OFFSET DIAGRAM

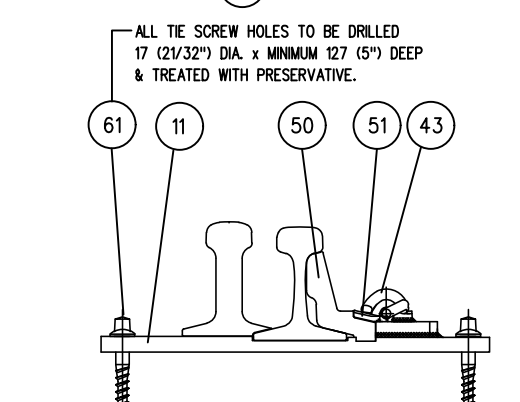

ADJUSTABLE RAIL BRACE ASSEMBLY

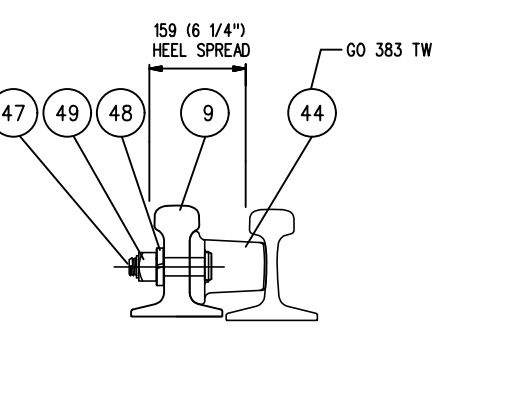

HEEL BLOCK ASSEMBLY

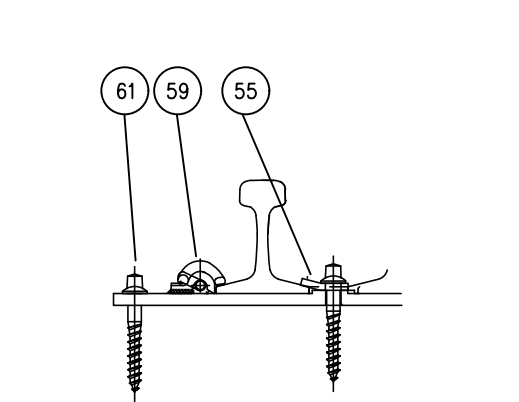

HOLD-DOWN CLIP ASSEMBLY

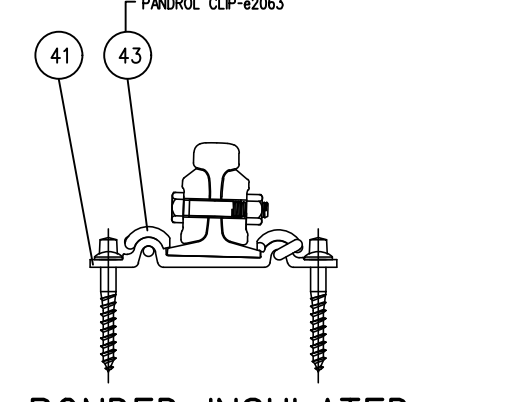

BONDED INSULATED RAIL JOINT

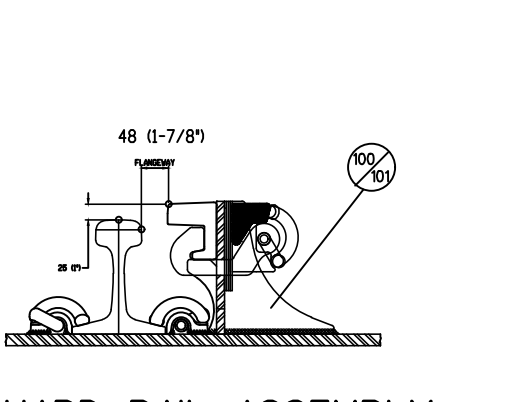

GUARD RAIL ASSEMBLY
FOR REPLACEMENT STOCK NUMBERS OF WEAR BARS SEE GTS-1122

TURNOUT DATA

FROG NO.	16
LENGTH OF SWITCH PT.	12370 (40'-7")
HEEL SPREAD	159 (6'-1/4")
LEAD	36093 (118'-5")
P.S. TO H.F.	40995 (134'-6")
19558 (64'-2")	STRAIGHT CLOSURE LENGTH
19590 (64'-3 1/4")	CURVED CLOSURE LENGTH

- NOTES:
- INFORMATION CONTAINED IN THIS PLAN IS FOR MAINTENANCE PURPOSE ONLY. ORDERING INFORMATION FOR NEW TURNOUTS CAN BE FOUND ON GTS-0278
 - WHEN REFERRING TO POWER OPERATED TURNOUTS, DRAWING NUMBER MUST BE STATED AS A,B,C OR D TO INDICATE:
A-RIGHT HAND TURNOUT P.O. MACHINE ON RIGHT
B-RIGHT HAND TURNOUT P.O. MACHINE ON LEFT
C-LEFT HAND TURNOUT P.O. MACHINE ON RIGHT
D-LEFT HAND TURNOUT P.O. MACHINE ON LEFT
 - FOR OTHER TURNOUT COMBINATIONS SEE INDEX GTS-0000 SHEETS 1 TO 3.
 - TURNOUT GEOMETRY, FOR TABLES OF DIMENSIONS AND OFFSETS SEE GTS-0004 NO.16

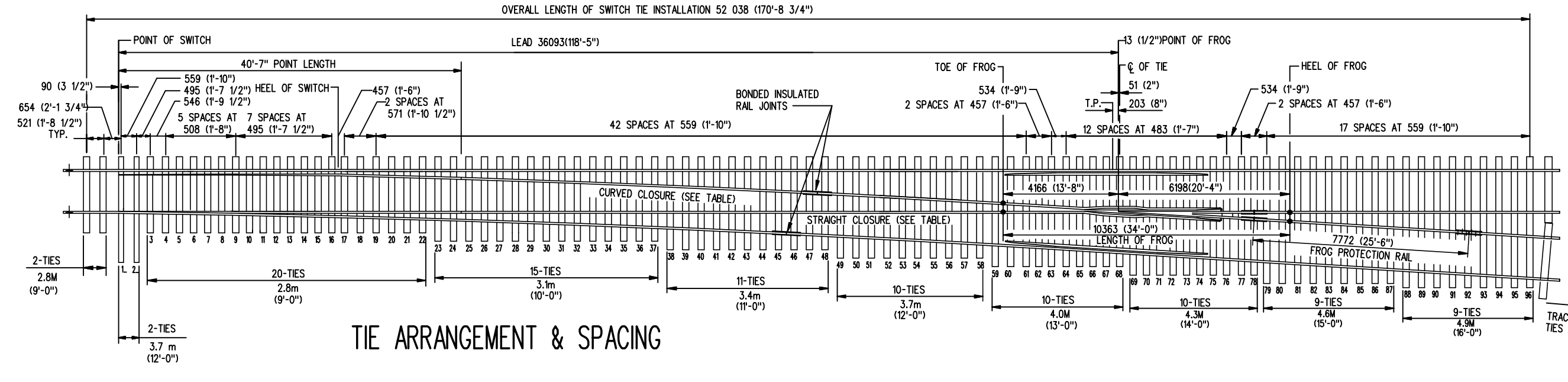

TIE ARRANGEMENT & SPACING

METRIC CONVERSION: 1 inch=25.4mm, 1 foot=304.8mm

No.	18/07/27	ADDED IMPERIAL TO METRIC CONVERSION NOTE
Date	Revision	By Approved

Standard NO. 16 TURNOUT-26'0" GEOMETRY
POWER OPERATED SAMSON POINT SWITCH
UNIFORM RISER DESIGN
RBM FROG-136 LB. RAIL-WOOD TIES

Drawn MG Checked GGS Approved VP Engineering & Asset Management

Date SEPT 15/2017 Plan Number GTS-0251 Rev 1
REFERENCE: TS-0251_R8 Sheet 1 OF 1

BILL OF MATERIALS FOR GTS-0251

ITEM	DESCRIPTION	MARK NUMBER	STANDARD DRAWING	QUANTITY			
				A	B	C	D
SWITCH PACK							
1	1st. GAUGE PLATE C/W INSULATION PLATE 136	GP100/GP100	GTS-0523	1	1	1	1
2	2nd. GAUGE PLATE C/W INSULATION PLATE 136	GP149/GP101	GTS-0523	1	-	-	-
	2nd. GAUGE PLATE C/W INSULATION PLATE 136	GP151/GP104	GTS-0523	-	1	-	-
	2nd. GAUGE PLATE C/W INSULATION PLATE 136	GP104/GP153	GTS-0523	-	-	1	-
	2nd. GAUGE PLATE C/W INSULATION PLATE 136	GP101/GP155	GTS-0523	-	-	-	1
3	3rd. GAUGE PLATE C/W INSULATION PLATE 136	GP150/GP101	GTS-0523	1	-	-	-
	3rd. GAUGE PLATE C/W INSULATION PLATE 136	GP152/GP104	GTS-0523	-	1	-	-
	3rd. GAUGE PLATE C/W INSULATION PLATE 136	GP104/GP154	GTS-0523	-	-	1	-
	3rd. GAUGE PLATE C/W INSULATION PLATE 136	GP101/GP156	GTS-0523	-	-	-	1
4	MILD STEEL STRAP	356A	GTS-0356A	1	1	1	1
5	MILD STEEL STRAP	356B	GTS-0356B	1	1	1	1
6	MILD STEEL STRAP	356C	GTS-0356C	1	1	1	1
7	SWITCH ROD	344B	GTS-0344B	1	1	1	1
8	SWITCH ROD	344D	GTS-0344D	2	2	2	2
9	RIGHT SAMSON POINT RAIL - THICK WEB		GTS-0377	1	1	-	-
	RIGHT SAMSON CURVED POINT RAIL - THICK WEB		GTS-0377	-	-	1	1
10	LEFT SAMSON POINT RAIL - THICK WEB		GTS-0377	-	-	1	1
	LEFT SAMSON CURVED POINT RAIL - THICK WEB		GTS-0377	1	1	-	-
11	SWITCH PLATE - SUREFIT BRACE PLATE	SP798	GTS-0508	8	8	8	8
12	ROLLER PLATE - SUREFIT BRACE PLATE	RP798	GTS-0508	2	2	2	2
13	SWITCH PLATE	SP363	GTS-0530	10	10	10	10
14	ROLLER PLATE	RP363	GTS-0530	6	6	6	6
15	SWITCH PLATE	SP198	GTS-0530	4	4	4	4
16	SWITCH PLATE (RIGHT SIDE for RIGHT HAND TURNOUT)	SP781R		1	1	-	-
	SWITCH PLATE (RIGHT SIDE for LEFT HAND TURNOUT)	SP780R		-	-	1	1
17	SWITCH PLATE (LEFT SIDE for RIGHT HAND TURNOUT)	SP780L		1	1	-	-
	SWITCH PLATE (LEFT SIDE for LEFT HAND TURNOUT)	SP781L		-	-	1	1
18	SWITCH PLATE (RIGHT SIDE for RIGHT HAND TURNOUT)	SP783R		1	1	-	-
	SWITCH PLATE (RIGHT SIDE for LEFT HAND TURNOUT)	SP782R		-	-	1	1
19	SWITCH PLATE (LEFT SIDE for RIGHT HAND TURNOUT)	SP782L		1	1	-	-
	SWITCH PLATE (LEFT SIDE for LEFT HAND TURNOUT)	SP783L		-	-	1	1
20	SWITCH PLATE (RIGHT SIDE for RIGHT HAND TURNOUT)	SP522R	GTS-0542	1	1	-	-
	SWITCH PLATE (RIGHT SIDE for LEFT HAND TURNOUT)	SP504R	GTS-0532	-	-	1	1
21	SWITCH PLATE (LEFT SIDE for RIGHT HAND TURNOUT)	SP504L	GTS-0532	1	1	-	-
	SWITCH PLATE (LEFT SIDE for LEFT HAND TURNOUT)	SP522L	GTS-0542	-	-	1	1
22	SWITCH PLATE (RIGHT SIDE for RIGHT HAND TURNOUT)	SP523R	GTS-0542	1	1	-	-
	SWITCH PLATE (RIGHT SIDE for LEFT HAND TURNOUT)	SP505R	GTS-0532	-	-	1	1
23	SWITCH PLATE (LEFT SIDE for RIGHT HAND TURNOUT)	SP505L	GTS-0532	1	1	-	-
	SWITCH PLATE (LEFT SIDE for LEFT HAND TURNOUT)	SP523L	GTS-0542	-	-	1	1
24	SWITCH PLATE (RIGHT SIDE for RIGHT HAND TURNOUT)	SP524R	GTS-0542	1	1	-	-
	SWITCH PLATE (RIGHT SIDE for LEFT HAND TURNOUT)	SP506R	GTS-0532	-	-	1	1
25	SWITCH PLATE (LEFT SIDE for RIGHT HAND TURNOUT)	SP506L	GTS-0532	1	1	-	-
	SWITCH PLATE (LEFT SIDE for LEFT HAND TURNOUT)	SP524L	GTS-0542	-	-	1	1
26	SWITCH PLATE (RIGHT SIDE for RIGHT HAND TURNOUT)	SP525R	GTS-0542	1	1	-	-
SWITCH PACK continued							
	SWITCH PLATE (RIGHT SIDE for LEFT HAND TURNOUT)	SP507R	GTS-0532	-	-	1	1
27	SWITCH PLATE (LEFT SIDE for RIGHT HAND TURNOUT)	SP507L	GTS-0532	1	1	-	-
	SWITCH PLATE (LEFT SIDE for LEFT HAND TURNOUT)	SP525L	GTS-0542	-	-	1	1
28	SWITCH PLATE (RIGHT SIDE for RIGHT HAND TURNOUT)	SP526R	GTS-0542	1	1	-	-
	SWITCH PLATE (RIGHT SIDE for LEFT HAND TURNOUT)	SP508R	GTS-0532	-	-	1	1
29	SWITCH PLATE (LEFT SIDE for RIGHT HAND TURNOUT)	SP508L	GTS-0532	1	1	-	-
	SWITCH PLATE (LEFT SIDE for LEFT HAND TURNOUT)	SP526L	GTS-0542	-	-	1	1
30	SWITCH PLATE (RIGHT HAND)	SP509R	GTS-0534	2	2	-	-
	SWITCH PLATE (LEFT HAND)	SP509L	GTS-0534	-	-	2	2
31	SWITCH PLATE (RIGHT HAND)	SP510R	GTS-0534	2	2	-	-
	SWITCH PLATE (LEFT HAND)	SP510L	GTS-0534	-	-	2	2
32	SWITCH PLATE (RIGHT HAND)	SP511R	GTS-0534	2	2	-	-
	SWITCH PLATE (LEFT HAND)	SP511L	GTS-0534	-	-	2	2
33	SWITCH PLATE (RIGHT HAND)	SP512R	GTS-0535	2	2	-	-
	SWITCH PLATE (LEFT HAND)	SP512L	GTS-0535	-	-	2	2
34	SWITCH PLATE (RIGHT HAND)	SP513R	GTS-0535	2	2	-	-
	SWITCH PLATE (LEFT HAND)	SP513L	GTS-0535	-	-	2	2
35	SWITCH PLATE (RIGHT HAND)	SP514R	GTS-0536	2	2	-	-
	SWITCH PLATE (LEFT HAND)	SP514L	GTS-0536	-	-	2	2
36	SWITCH PLATE (RIGHT HAND)	SP515R	GTS-0536	2	2	-	-
	SWITCH PLATE (LEFT HAND)	SP515L	GTS-0536	-	-	2	2
37	SWITCH PLATE (RIGHT HAND)	SP516R	GTS-0536	2	2	-	-
	SWITCH PLATE (LEFT HAND)	SP516L	GTS-0536	-	-	2	2
38	SWITCH PLATE (RIGHT HAND)	SP517R	GTS-0536	2	2	-	-
	SWITCH PLATE (LEFT HAND)	SP517L	GTS-0536	-	-	2	2
39	SWITCH PLATE (RIGHT HAND)	SP518R	GTS-0536	2	2	-	-
	SWITCH PLATE (LEFT HAND)	SP518L	GTS-0536	-	-	2	2
40	SWITCH PLATE (RIGHT HAND)	SP519R	GTS-0536	2	2	-	-
	SWITCH PLATE (LEFT HAND)	SP519L	GTS-0536	-	-	2	2
41	ROLLED PANDROL PLATE	ROLLED	GTS-0501	68	68	68	68
43	PANDROL CLIP - e2063 (for INSULATED RAIL JOINTS)	e2063	GTS-1322	8	8	8	8
44	HEEL BLOCK - SYMMETRICAL FOR THICK WEB POINT	CN383-TW	GTS-383	2	2	2	2
47	BOLT, 1 1/8" DIA X 5-1/2" LONG, 7 UNC C/W NUT	GTS1308/10	GTS-1308	4	4	4	4
48	SPRING WASHER for 1-1/8" DIA BOLT	-	GTS-1301	4	4	4	4
49	LOCKNUT FOR 1-1/8" DIA. - 7 UNC BOLT	-	GTS-1302	4	4	4	4
50	SUREFIT BOLTLESS ADJUSTABLE RAIL BRACE	-	GTS-0354	16	16	16	16
51	SERRATED WASHER FOR BOLTLESS ADJUSTABLE BRACE	-	GTS-0354	32	32	32	32
55	HOLD DOWN CLIP	FS156	GTS-1334	20	20	20	20
59	PANDROL CLIP - e2055	e2055	GTS-1322	290	290	290	290
61	SCREW SPIKE - POINTED	Ss5	GTS-1315	590	590	590	590
62	UNDERCUT STOCK RAIL - 136 LB. R.E. 39'-0" LG.	1105H	GTS-1105H	1	1	1	1
63	BENT UNDERCUT STOCK RAIL - R/H - 136 LB. R.E. 39'-0" LG.	1109E	GTS-1109E	1	1	-	-
	BENT UNDERCUT STOCK RAIL - L/H - 136 LB. R.E. 39'-0" LG.	1109F	GTS-1109F	-	-	1	1
FROG							
64	#16-136 LB. RAIL BOUND MANGANESE STEEL FROG	0	0	1	1	1	1
	MAINTENANCE LENGTH FROG - CUT TO SHORTEST LENGTH						
FROG PACK				0	0		
65	FROG BASE PLATE (RIGHT HAND)	FP527R	GTS-0603	1	1	-	-
	FROG BASE PLATE (LEFT HAND)	FP527L	GTS-0603	-	-	1	1
66	FROG PLATE	FP434	GTS-0601	1	1	1	1
67	FROG BASE PLATE (RIGHT HAND)	FP529R	GTS-0604	1	1	-	-
	FROG BASE PLATE (LEFT HAND)	FP529L	GTS-0604	-	-	1	1
68	FROG PLATE (RIGHT HAND)	FP530R	GTS-0601	1	1	-	-
	FROG PLATE (LEFT HAND)	FP530L	GTS-0601	-	-	1	1
69	1" DIA. - 8 UNC SQ. HEAD SQ. NECK CARRIAGE BOLT X 3-1/2" LG.	-	GTS-1307/1	16	16	16	16
70	SPRING WASHER for 1" DIA. BOLT	-	GTS-1301	16	16	16	16
71	PLATE WASHER for 1" DIA. BOLT	-	GTS-1337	16	16	16	16
72	INSULATION PLATE	136	GTS-0526	4	4	4	4
73	FROG PLATE (RIGHT HAND)	FP513R	GTS-0547	1	1	-	-
	FROG PLATE (LEFT HAND)	FP513L	GTS-0547	-	-	1	1
74	FROG PLATE (RIGHT HAND)	FP514R	GTS-0547	1	1	-	-
	FROG PLATE (LEFT HAND)	FP514L	GTS-0547	-	-	1	1
75	FROG PLATE (RIGHT HAND)	FP515R	GTS-0547	1	1	-	-
	FROG PLATE (LEFT HAND)	FP515L	GTS-0547	-	-	1	1
76	FROG PLATE (RIGHT HAND)	FP516R	GTS-0547	1	1	-	-
	FROG PLATE (LEFT HAND)	FP516L	GTS-0547	-	-	1	1
77	FROG PLATE (RIGHT HAND)	FP517R	GTS-0547	1	1	-	-
	FROG PLATE (LEFT HAND)	FP517L	GTS-0547	-	-	1	1
78	FROG PLATE (RIGHT HAND)	FP518R	GTS-0547	1	1	-	-
	FROG PLATE (LEFT HAND)	FP518L	GTS-0547	-	-	1	1
79	FROG PLATE (RIGHT HAND)	FP519R	GTS-0546	1	1	-	-
	FROG PLATE (LEFT HAND)	FP519L	GTS-0546	-	-	1	1
80	FROG PLATE (RIGHT HAND)	FP520R	GTS-0556	1	1	-	-
	FROG PLATE (LEFT HAND)	FP520L	GTS-0556	-	-	1	1
81	FROG PLATE (RIGHT HAND)	FP521R	GTS-0546	1	1	-	-
	FROG PLATE (LEFT HAND)	FP521L	GTS-0546	-	-	1	1
82	FROG PLATE (RIGHT HAND)	FP522R	GTS-0546	1	1	-	-
	FROG PLATE (LEFT HAND)	FP522L	GTS-0546	-	-	1	1
83	FROG PLATE (RIGHT HAND)	FP523R	GTS-0547	1	1	-	-
	FROG PLATE (LEFT HAND)	FP523L	GTS-0547	-	-	1	1
84	FROG PLATE (RIGHT HAND)	FP524R	GTS-0547	1	1	-	-
	FROG PLATE (LEFT HAND)	FP524L	GTS-0547	-	-	1	1
85	FROG PLATE (RIGHT HAND)	FP525R	GTS-0547	1	1	-	-
	FROG PLATE (LEFT HAND)	FP525L	GTS-0547	-	-	1	1
86	FROG PLATE (RIGHT HAND)	FP526R	GTS-0547	1	1	-	-
	FROG PLATE (LEFT HAND)	FP526L	GTS-0547	-	-	1	1
87	FROG PLATE (RIGHT HAND)	FP531R	GTS-0554	1	1	-	-
FROG PACK continued							
	FROG PLATE (LEFT HAND)	FP531L	GTS-0554	-	-	1	1
88	FROG BASE PLATE (RIGHT HAND)	FP532R	GTS-0596	1	1	-	-
	FROG BASE PLATE (LEFT HAND)	FP532L	GTS-0596	-	-	1	1

BILL OF MATERIALS FOR GTS-0251

ITEM	DESCRIPTION	MARK NUMBER	STANDARD DRAWING	QUANTITY			
				A	B	C	D
89	FROG BASE PLATE (RIGHT HAND)	FP533R	GTS-0597	1	1	-	-
	FROG BASE PLATE (LEFT HAND)	FP533L	GTS-0597	-	-	1	1
90	FROG BASE PLATE (RIGHT HAND)	FP534R	GTS-0598	1	1	-	-
	FROG BASE PLATE (LEFT HAND)	FP534L	GTS-0598	-	-	1	1
91	FROG PLATE (RIGHT HAND)	FP535R	GTS-0554	1	1	-	-
	FROG PLATE (LEFT HAND)	FP535L	GTS-0554	-	-	1	1
92	ROLLED PANDROL PLATE	ROLLED	GTS-0501	26	26	26	26
93	1-1/8" DIA. - 7 UNC SQ. HD. BOLT X 6" LG. C/W SQ. NUT	-	GTS-1309/32	2	2	2	2
95	PANDROL CLIP - e2055	e2055	GTS-1322	150	150	150	150
96	SCREW SPIKE - POINTED	Ss5	GTS-1315	280	280	280	280
97	STRAIGHT SPLICE BAR (6 HOLE) - 132/136 LB. R.E.	-	GTS-1203	5	5	5	5
98	SPRING WASHER for 1-1/8" DIA BOLT	-	GTS-1301	30	30	30	30
99	1-1/8" DIA. - 7 NC OVAL NECK TRACK BOLT X 5-7/8" LG. C/W SQ NUT	-	GTS-1320/1	30	30	30	30
	GUARD RAIL PACK						
100	#16 GUARD RAIL ASSY.-RIGHT SIDE FOR RIGHT HAND TURNOUT	-	GTS-1123	1	1	-	-
	#16 GUARD RAIL ASSY.-LEFT SIDE FOR LEFT HAND TURNOUT	-	GTS-1123	-	-	1	1
101	#16 GUARD RAIL ASSY. STRAIGHT SIDE	-	GTS-1123	1	1	1	1
102	ROLLED PANDROL PLATE	ROLLED	GTS-0501	60	60	60	60
103	PANDROL CLIP - e2055	e2055	GTS-1322	120	120	120	120
104	SCREW SPIKE - POINTED	Ss5	GTS-1315	360	360	360	360
	SWITCH TIES						
	9 ft (2.8 m)			22	22	22	22
	10 ft (3.1 m)			15	15	15	15
	11 ft (3.4 m)			11	11	11	11
	12 ft (3.7 m)			12	12	12	12
	13 ft (4.0 m)			10	10	10	10
	14 ft (4.3 m)			10	10	10	10
	15 ft (4.6 m)			9	9	9	9
	16 ft (4.9 m)			9	9	9	9
	FOR SWITCH PACKS, FROG PACKS AND GUARD RAIL PACKS PLEASE SEE GTS-0274						