

TIE ARRANGEMENT & SPACING

TURNOUT DATA

FROG NO. 12  
 LENGTH OF SWITCH PT. 11151 (36'-7")  
 HEEL SPREAD 159 (6 1/4")  
 LEAD 29896 (98'-1")  
 P.S. TO H.F. 34430 (112'-11 1/2")

RBM FROG  
 15659 (51'-4 1/2") STRAIGHT CLOSURE LENGTHS  
 15704 (51'-6 9/32") CURVED CLOSURE LENGTH

SPRING FROG  
 13487 (44'-3") STRAIGHT CLOSURE LENGTHS  
 13533 (44'-4 25/32") CURVED CLOSURE LENGTH

FROGS	RBM	SPRING
A	3086 (10'-1 1/2")	5258 (17'-3")
B	4534 (14'-10 1/2")	4547 (14'-11")
C	7620 (25')	9804 (32'-2")

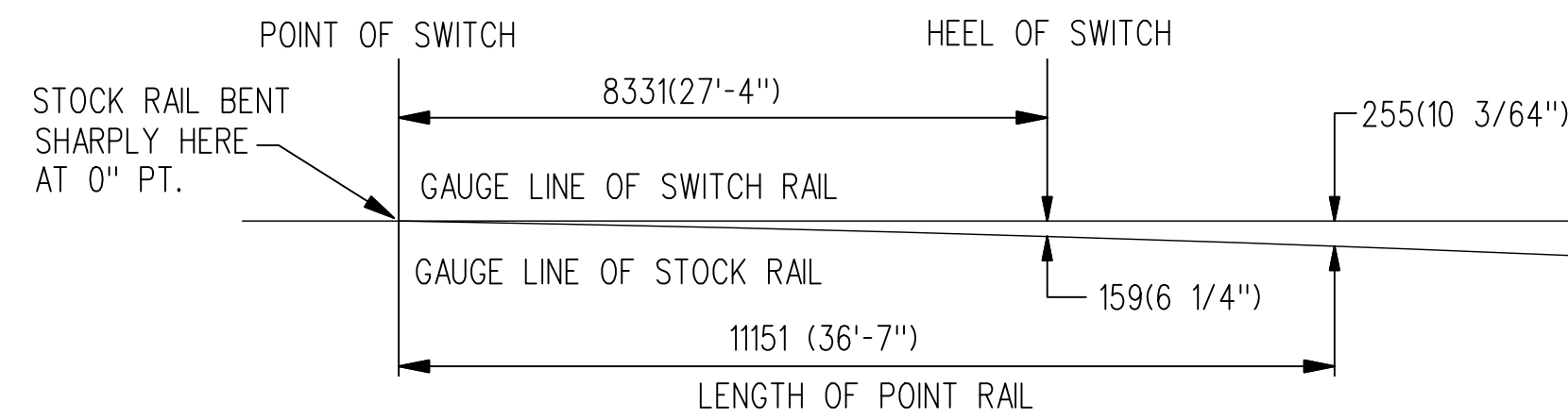

STOCK RAIL BENDING DETAIL

NOTES:

- TURNOUT TO BE INSTALLED AND MAINTAINED IN ACCORDANCE WITH THE LATEST ISSUE OF THE RM.
- WHEN REFERRING TO POWER OPERATED TURNOUTS, DRAWING NUMBER MUST BE STATED AS INDICATED:  
 L-LEFT HAND TURNOUT P.O. MACHINE ON LEFT OR RIGHT - RBM FROG  
 M-LEFT HAND TURNOUT P.O. MACHINE ON LEFT OR RIGHT - SPRING FROG  
 R-RIGHT HAND TURNOUT P.O. MACHINE ON LEFT OR RIGHT - RBM FROG  
 S-RIGHT HAND TURNOUT P.O. MACHINE ON LEFT OR RIGHT - SPRING FROG
- FOR OTHER TURNOUT COMBINATIONS SEE INDEX GTS-0000 SHEET 3 OF 3
- TURNOUT GEOMETRY, FOR TABLES OF DIMENSIONS AND OFFSETS SEE GTS-0003A NO. 12 ALL WELDED TURNOUTS.

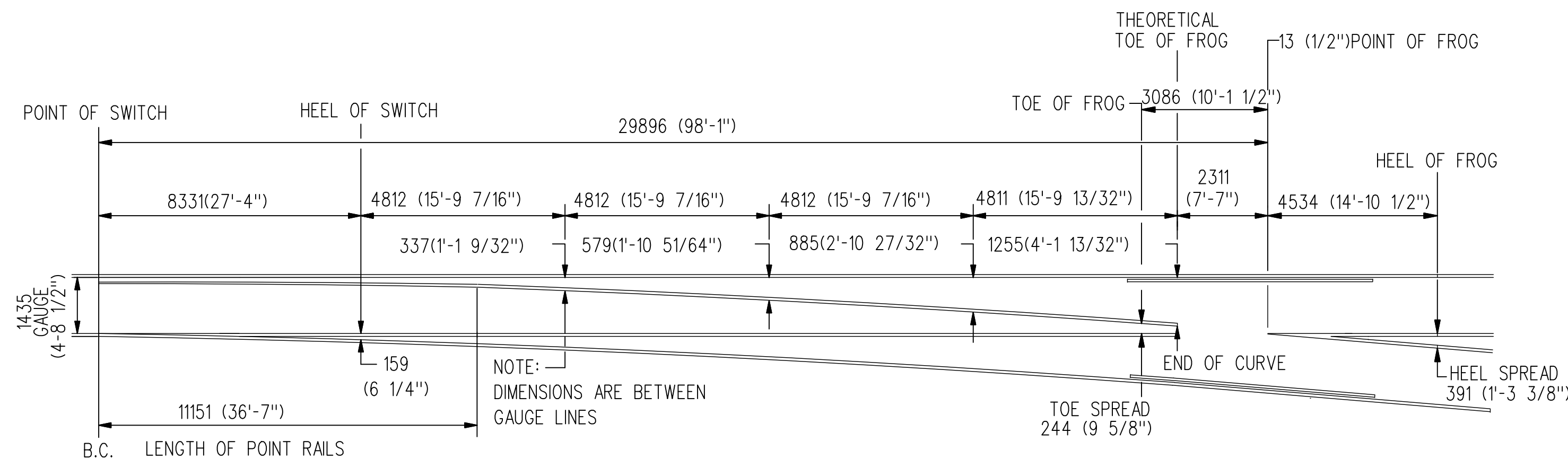

OFFSET DIAGRAM

METRIC CONVERSION: 1 inch=25.4mm, 1 foot=304.8mm

No.	18/07/27	ADDED IMPERIAL TO METRIC CONVERSION NOTE	By Approved
No.	Date	Revision	By Approved

Standard NO. 12 TURNOUT-136 LB. RAIL  
 36'7" POWER OPERATED-SAMSON POINT SWITCH  
 UNIFORM RISER DESIGN-ALL WELDED  
 R.B.M. FROG-WOOD TIES

Drawn RL Checked JR Approved VP Engineering & Asset Management



Date SEPT 15/2017 Plan Number GTS-0271 Rev 1

REFERENCE: TS-0271\_R9 Sheet 1 OF 2

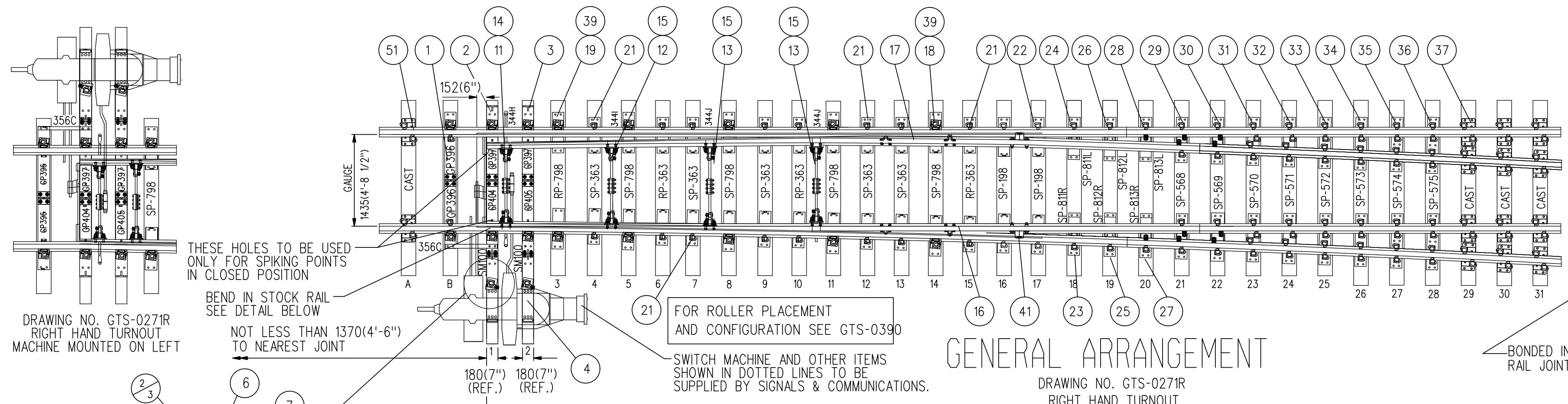

DRAWING NO. GTS-0271R  
RIGHT HAND TURNOUT  
MACHINE MOUNTED ON LEFT

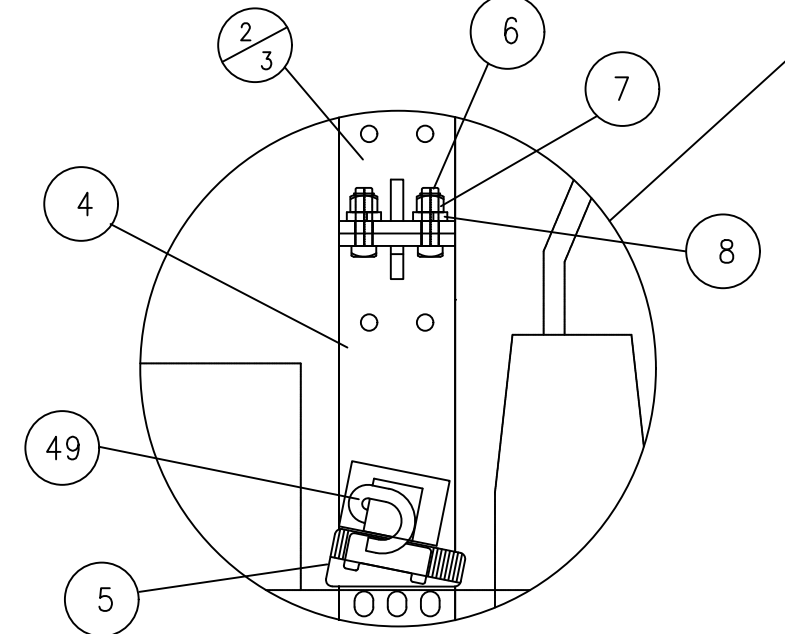
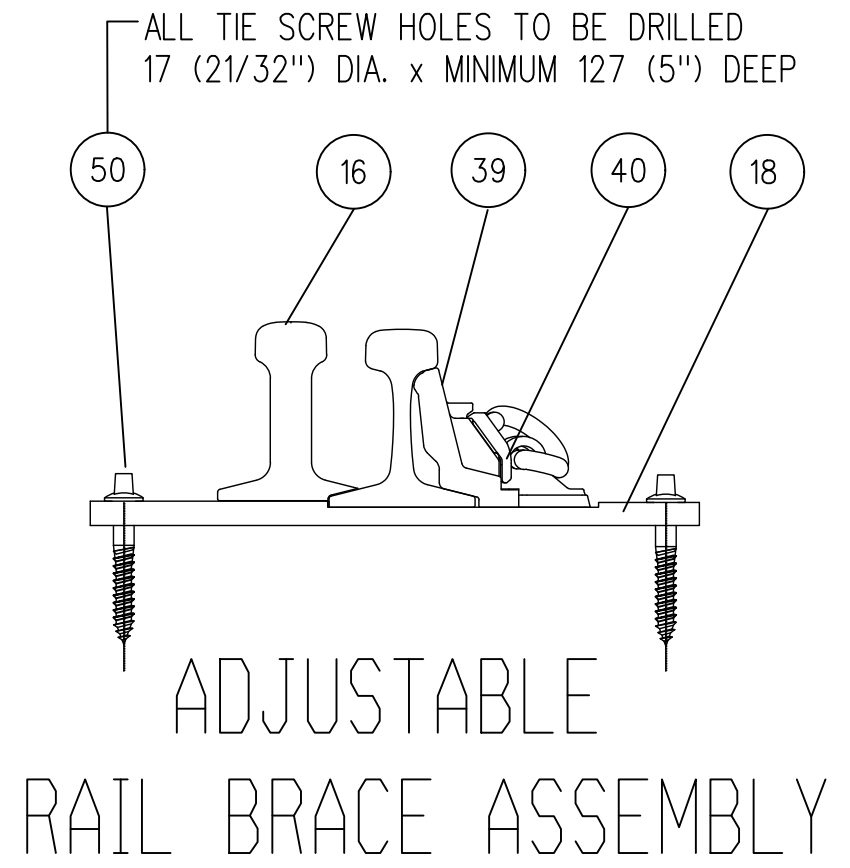

GENERAL ARRANGEMENT

DRAWING NO. GTS-0271R  
RIGHT HAND TURNOUT

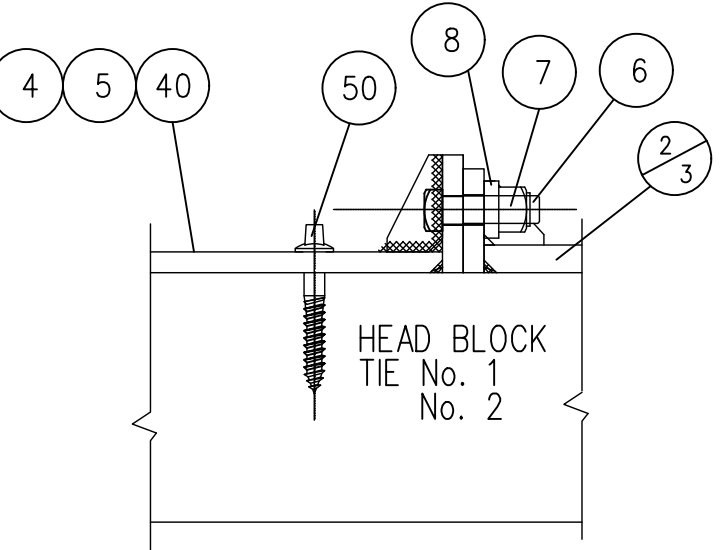
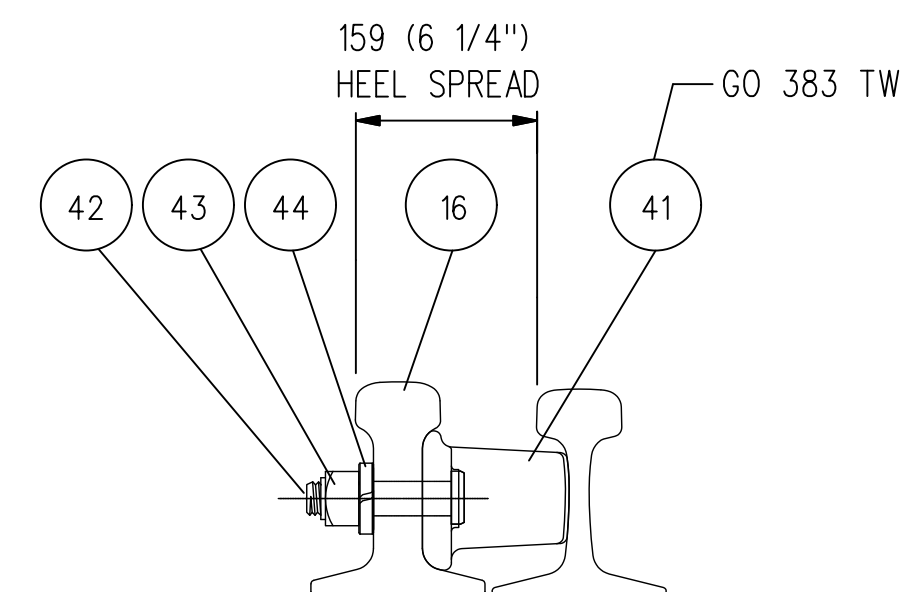

FOR REPLACEMENT OF CLIPS OR STOPS IN FIELD SEE GTS-0378

FOR CLIP ASSEMBLY SEE GTS-0352

SWITCH ROD

UNDERCUT STOCK RAIL

SWITCH POINT THROWS  
POWER OPERATED SWITCHES

- @ 1st ROD- 121 (4 3/4") ±1/16"
- @ 2nd ROD- 96 (3 25/32") ±1/16"
- @ 3rd ROD- 73 (2 7/8") ±1/16"
- @ 4th ROD- 50 (1 31/32") ±1/16"

ROCKER CLIP ASSEMBLY

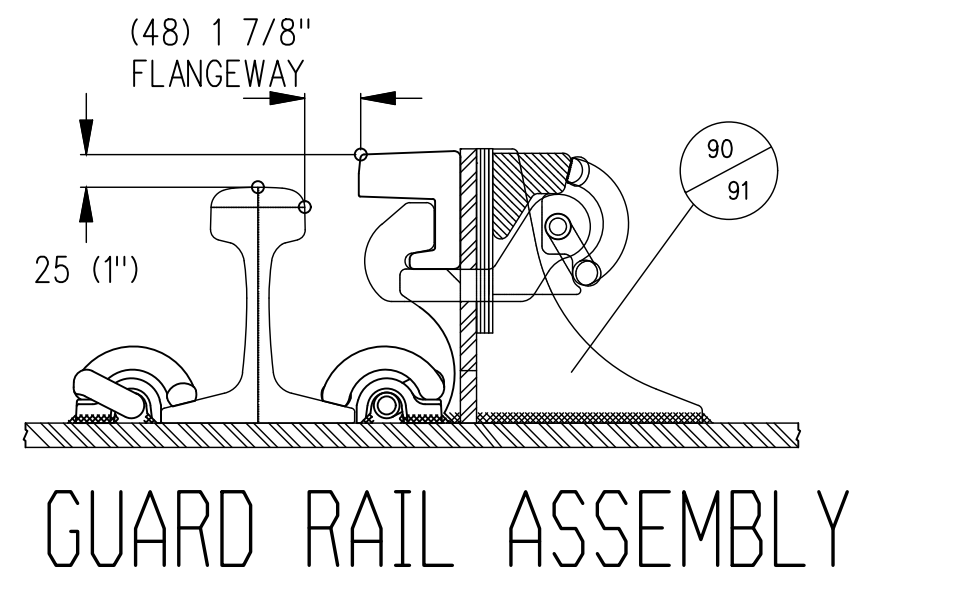
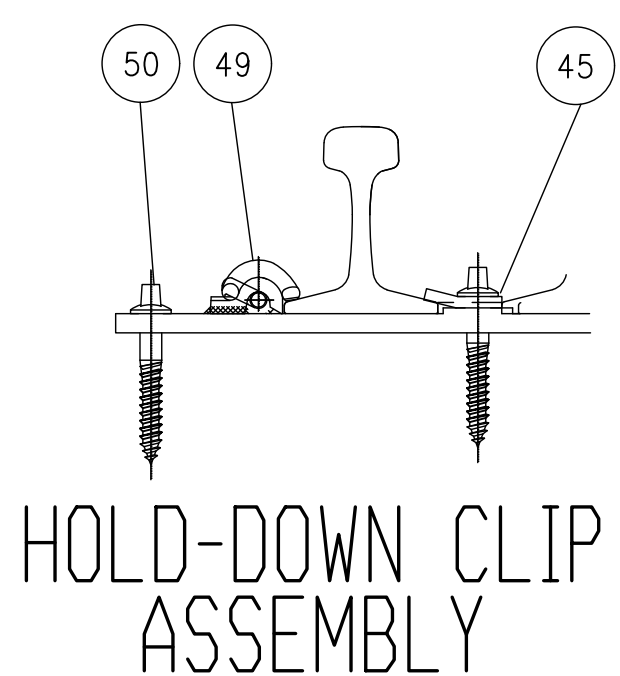
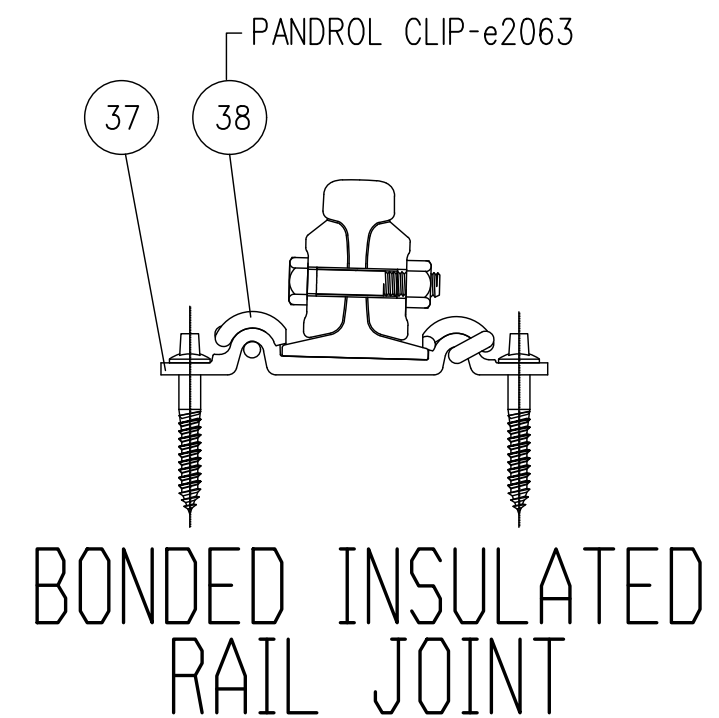
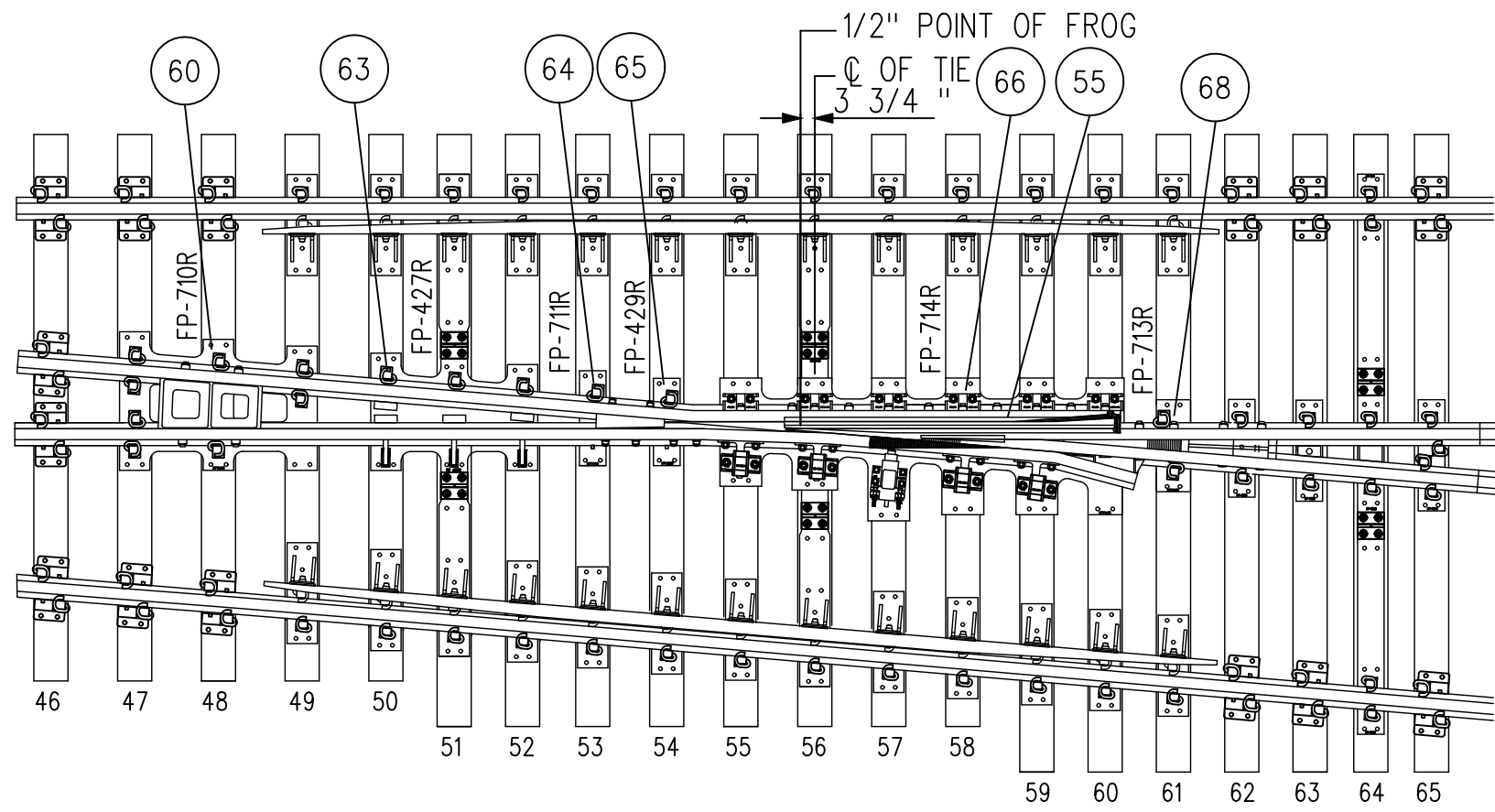
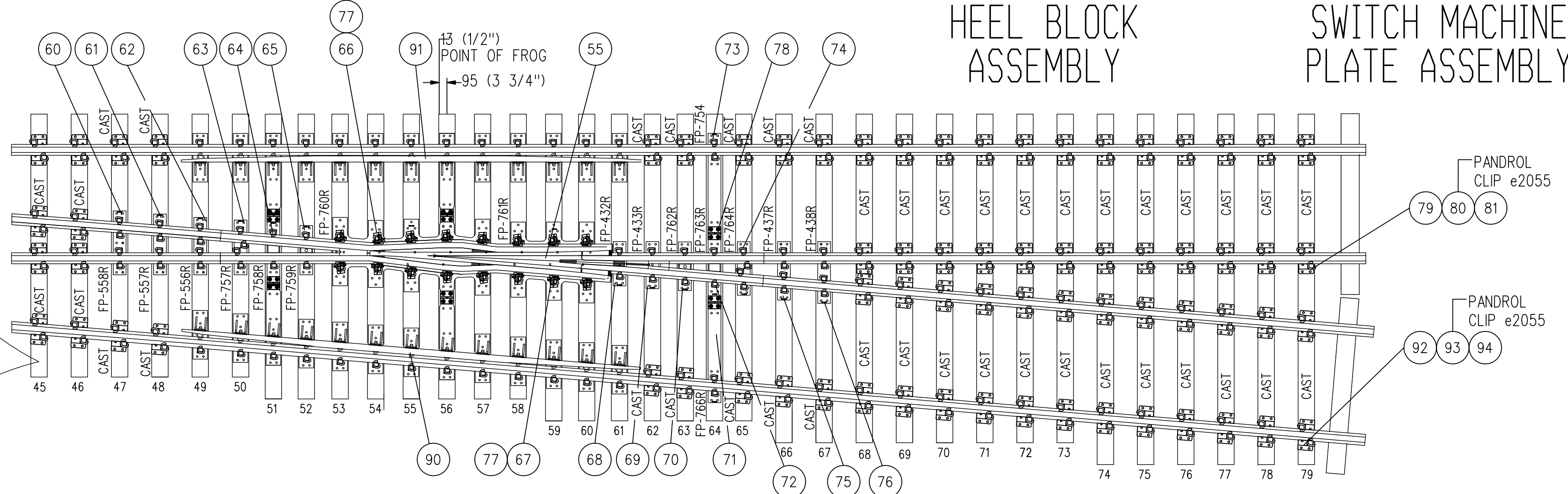

METRIC CONVERSION: 1 inch=25.4mm, 1 foot=304.8mm

No.	Date	Revision	By	Approved
1	18/07/27	ADDED IMPERIAL TO METRIC CONVERSION NOTE		

Standard

NO. 12 TURNOUT-136 LB. RAIL  
36'7" POWER OPERATED-SAMSON POINT SWITCH  
UNIFORM RISER DESIGN-ALL WELDED  
R.B.M. FROG-WOOD TIES

Drawn RL Checked JR Approved VP Engineering & Asset Management



Date SEPT 15/2017 Plan Number GTS-0271 Rev 1

REFERENCE: TS-0271\_R9 Sheet 2 OF 2

**BILL OF MATERIALS FOR GTS-0271**

ITEM	DESCRIPTION	MARK NUMBER	STANDARD DRAWING	QUANTITY			
				L	M	R	S
<b>SWITCH PACK</b>							
1	1st. GAUGE PLATE ASSEMBLY	GP396/GP396	GTS-0523	1	1	1	1
2	2nd. GAUGE PLATE ASSEMBLY	GP397/GP404	GTS-0523	-	-	1	1
	2nd. GAUGE PLATE ASSEMBLY	GP402/GP397	GTS-0523	1	1	-	-
3	3rd. GAUGE PLATE ASSEMBLY	GP397/GP405	GTS-0523	-	-	1	1
	3rd. GAUGE PLATE ASSEMBLY	GP403/GP397	GTS-0523	1	1	-	-
4	SWITCH MACHINE PLATE	SM100	GTS-0520	2	2	2	2
5	SWITCH MACHINE PLATE CLAMP (includes serrated washer)	-	GTS-0520	2	2	2	2
6	1" DIA. - 8 UNC SQ.HD. BOLT X 3-1/2" LG. C/W SQ. NUT	-	GTS-1309/13	4	4	4	4
7	LOCKNUT FOR 1" DIA. - 8 UNC BOLT	-	GTS-1302	4	4	4	4
8	SPRING WASHER for 1" DIA. BOLT	-	GTS-1301	4	4	4	4
10	MILD STEEL STRAP	356C	GTS-0356C	1	1	1	1
11	SWITCH ROD	344H	GTS-0344H	1	1	1	1
12	SWITCH ROD	344I	GTS-0344I	1	1	1	1
13	SWITCH ROD	344J	GTS-0344J	2	2	2	2
14	ROCKER CLIP ASSEMBLY	352L	GTS-0352L	2	2	2	2
15	ROCKER CLIP ASSEMBLY	352M	GTS-0352M	6	6	6	6
16	RIGHT SAMSON POINT RAIL - THICK WEB	-	GTS-0378	-	-	1	1
	RIGHT SAMSON CURVED POINT RAIL - THICK WEB	-	GTS-0378	1	1	-	-
17	LEFT SAMSON POINT RAIL - THICK WEB	-	GTS-0378	1	1	-	-
	LEFT SAMSON CURVED POINT RAIL - THICK WEB	-	GTS-0378	-	-	1	1
18	SWITCH PLATE - LV/CLAMPTITE BRACE	SP798	GTS-0508	8	8	8	8
19	ROLLER PLATE - LV/CLAMPTITE BRACE	RP798	GTS-0508	2	2	2	2
20	SWITCH PLATE	SP363	GTS-0530	10	10	10	10
21	ROLLER PLATE	RP363	GTS-0530	6	6	6	6
22	SWITCH PLATE	SP198	GTS-0530	4	4	4	4
23	SWITCH PLATE (RIGHT HAND)	SP811R	GTS-0586/1	1	1	1	1
24	SWITCH PLATE (LEFT HAND)	SP811L	GTS-0586/2	1	1	1	1
25	SWITCH PLATE (RIGHT HAND)	SP812R	GTS-0586/1	1	1	1	1
26	SWITCH PLATE (LEFT HAND)	SP812L	GTS-0586/2	1	1	1	1
27	SWITCH PLATE (RIGHT HAND)	SP813R	GTS-0586/3	1	1	1	1
28	SWITCH PLATE (LEFT HAND)	SP813L	GTS-0586/4	1	1	1	1
29	SWITCH PLATE (UNIVERSAL)	SP568	GTS-0560/1	2	2	2	2
30	SWITCH PLATE (UNIVERSAL)	SP569	GTS-0560/1	2	2	2	2
31	SWITCH PLATE (UNIVERSAL)	SP570	GTS-0560/2	2	2	2	2
32	SWITCH PLATE (UNIVERSAL)	SP571	GTS-0560/2	2	2	2	2
33	SWITCH PLATE (UNIVERSAL)	SP572	GTS-0560/2	2	2	2	2
34	SWITCH PLATE (UNIVERSAL)	SP573	GTS-0560/2	2	2	2	2
35	SWITCH PLATE (UNIVERSAL)	SP574	GTS-0560/2	2	2	2	2
36	SWITCH PLATE (UNIVERSAL)	SP575	GTS-0560/2	2	2	2	2
37	CAST TIE PLATE	CAST	GTS-0501	74	74	74	74
<b>SWITCH PACK continued</b>							
38	PANDROL CLIP - e2063 (for INSULATED RAIL JOINTS)	e2063	GTS-1322	8	8	8	8
39	BOLTLESS ADJUSTABLE LV/CLAMPTITE BRACE	-		16	16	16	16
40	SERRATED WASHER FOR BOLTLESS ADJUSTABLE LV/CLAMPTITE BRACE	-		18	18	18	18
41	HEEL BLOCK - SYMMETRICAL FOR THICK WEB POINT	CN383-TW	GTS-0383	2	2	2	2
42	BOLT, 1 1/8" DIA X 5-1/2" LONG, 7 UNC C/W NUT	TS1308/10	GTS-1308	4	4	4	4
43	LOCKNUT FOR 1-1/8" DIA. - 7 UNC BOLT	-	GTS-1302	4	4	4	4
44	SPRING WASHER for 1-1/8" DIA BOLT	-	GTS-1301	4	4	4	4
45	HOLD DOWN CLIP	FS156	GTS-1334	10	10	10	10
49	PANDROL CLIP - e2055	e2055	GTS-1322	250	250	250	250
50	SCREW SPIKE - POINTED	COMMON STANDARD	GTS-1315	550	550	550	550
51	UNDERCUT STOCK RAIL - LEFT HAND - 136 LB. R.E. 39'- 0" LG.	1105M	GTS-1105M	-	-	1	1
	UNDERCUT STOCK RAIL - RIGHT HAND - 136 LB. R.E. 39'- 0" LG.	1105Q	GTS-1105Q	1	1	-	-
52	BENT UNDERCUT STOCK RAIL - R/H - 136 LB. R.E. 39'- 0" LG.	1109HH	GTS-1109HH	-	-	1	1
	BENT UNDERCUT STOCK RAIL - L/H - 136 LB. R.E. 39'- 0" LG.	1109JJ	GTS-1109JJ	1	1	-	-
<b>FROG</b>							
55	#12-136 LB. RAIL BOUND MANGANESE STEEL FROG 25'		GTS-0886	1	-	1	-
	MAINTENANCE LENGTH FROG - CUT TO SHORTEST LENGTH			-	1	-	-
	#12-136 LB. LH ALL-WELDED SPRING FROG 32'-2"			-	-	-	1
	MAINTENANCE LENGTH FROG - CUT TO SHORTEST LENGTH			-	-	-	-
	#12-136 LB. RH ALL-WELDED SPRING FROG 32'-2"			-	-	-	1
	MAINTENANCE LENGTH FROG - CUT TO SHORTEST LENGTH			-	-	-	-
<b>FROG PACK</b>							
60	FROG PLATE (RIGHT HAND)	FP558R	GTS-0547	-	-	1	-
	FROG PLATE (LEFT HAND)	FP558L	GTS-0547	1	-	-	-
	FROG PLATE SPRING (RIGHT HAND) <i>included in new frog</i>	FP710R		-	-	-	1
	FROG PLATE SPRING (LEFT HAND) <i>included in new frog</i>	FP710L		-	1	-	-
61	FROG PLATE (RIGHT HAND)	FP557R	GTS-0546	-	-	1	-
	FROG PLATE (LEFT HAND)	FP557L	GTS-0546	1	-	-	-
62	FROG PLATE (RIGHT HAND)	FP556R	GTS-0556	-	-	1	-
	FROG PLATE (LEFT HAND)	FP556L	GTS-0556	1	-	-	-
63	FROG PLATE (RIGHT HAND)	FP757R	GTS-0556/1	-	-	1	-
	FROG PLATE (LEFT HAND)	FP757L	GTS-0556/2	1	-	-	-
	FROG PLATE SPRING (RIGHT HAND) <i>included in new frog</i>	FP427R		-	-	-	1
	FROG PLATE SPRING (LEFT HAND) <i>included in new frog</i>	FP427L		-	1	-	-
64	FROG PLATE (RIGHT HAND)	FP758R	GTS-0670/1	-	-	1	-
	FROG PLATE (LEFT HAND)	FP758L	GTS-0670/1	1	-	-	-
	FROG PLATE SPRING (RIGHT HAND) <i>included in new frog</i>	FP711R		-	-	-	1
	FROG PLATE SPRING (LEFT HAND) <i>included in new frog</i>	FP711L		-	1	-	-
65	FROG PLATE (RIGHT HAND)	FP759R	GTS-0615/1	-	-	1	-
<b>FROG PACK continued</b>							
	FROG PLATE (LEFT HAND)	FP759L	GTS-0615/2	1	-	-	-
	FROG PLATE SPRING (RIGHT HAND) <i>included in new frog</i>	FP429R		-	-	-	1
	FROG PLATE SPRING (LEFT HAND) <i>included in new frog</i>	FP429L		-	1	-	-
66	FROG PLATE (RIGHT HAND)	FP760R	GTS-0590	-	-	1	-
	FROG PLATE (LEFT HAND)	FP760L	GTS-0590	1	-	-	-
	FROG PLATE SPRING (RIGHT HAND) <i>included in new frog</i>	FP714R		-	-	-	1
	FROG PLATE SPRING (LEFT HAND) <i>included in new frog</i>	FP714L		-	1	-	-
67	FROG PLATE (RIGHT HAND)	FP761R	GTS-0591	-	-	1	-
	FROG PLATE (LEFT HAND)	FP761L	GTS-0591	1	-	-	-
68	FROG PLATE (RIGHT HAND)	FP432R	GTS-0554	-	-	1	-
	FROG PLATE (LEFT HAND)	FP432L	GTS-0554	1	-	-	-
	FROG PLATE SPRING (RIGHT HAND) <i>included in new frog</i>	FP713R		-	-	-	1
	FROG PLATE SPRING (LEFT HAND) <i>included in new frog</i>	FP713L		-	1	-	-
69	FROG PLATE (RIGHT HAND)	FP433R	GTS-0554	-	-	1	1
	FROG PLATE (LEFT HAND)	FP433L	GTS-0554	1	1	-	-
70	FROG PLATE (RIGHT HAND)	FP762R	GTS-0615/1	-	-	1	1
	FROG PLATE (LEFT HAND)	FP762L	GTS-0615/2	1	1	-	-

**BILL OF MATERIALS FOR GTS-0271**

ITEM	DESCRIPTION	MARK NUMBER	STANDARD DRAWING	QUANTITY			
				L	M	R	S
71	FROG PLATE (RIGHT HAND)	FP766R	GTS-0662/1	-	-	1	1
	FROG PLATE (LEFT HAND)	FP766L	GTS-0662/2	1	1	-	-
72	FROG PLATE (RIGHT HAND)	FP763R	GTS-0670/1	-	-	1	1
	FROG PLATE (LEFT HAND)	FP763L	GTS-0670/1	1	1	-	-
73	FROG PLATE (UNIVERSAL)	FP754	GTS-0662/1	1	1	1	1
74	FROG PLATE (RIGHT HAND)	FP764R	GTS-0556/1	-	-	1	1
	FROG PLATE (LEFT HAND)	FP764L	GTS-0556/2	1	1	-	-
75	FROG PLATE (RIGHT HAND)	FP437R	GTS-0546	-	-	1	1
	FROG PLATE (LEFT HAND)	FP437L	GTS-0546	1	1	-	-
76	FROG PLATE (RIGHT HAND)	FP438R	GTS-0546	-	-	1	1
	FROG PLATE (LEFT HAND)	FP438L	GTS-0546	1	1	-	-
77	PANDROL FROG CLAMP INCLUDES SERRATED WASHER		GTS-0365	16	16	16	16
78	INSULATION KIT FOR 3/4" THICK PLATE c/w HARDWARE	-	GTS-0526	6	6	6	6
79	CAST TIE PLATE	CAST	GTS-0501	24	24	24	24
80	PANDROL CLIP - e2055	e2055	GTS-1322	110	110	110	110
81	SCREW SPIKE - POINTED	COMMON STANDARD	GTS-1315	220	220	220	220
	<b>GUARD RAIL PACK</b>						
90	#12L GUARD RAIL ASSY.-RIGHT SIDE FOR RIGHT HAND TURNOUT		GTS-1123	-	-	1	1
	#12L GUARD RAIL ASSY.-LEFT SIDE FOR LEFT HAND TURNOUT		GTS-1123	1	1	-	-
91	GUARD RAIL ASSY.- STRAIGHT SIDE		GTS-1123	1	1	1	1
92	CAST TIE PLATE	CAST	GTS-0501	38	38	38	38
93	PANDROL CLIP - e2055	e2055	GTS-1322	160	160	160	160
94	SCREW SPIKE - POINTED	COMMON STANDARD	GTS-1315	300	300	300	300
	<b>SWITCH PACKS</b>						
	#12 - 136, Power Operated - Right Hand Turnout						
	#12 - 136, Power Operated - Left Hand Turnout						
	<b>FROG PACKS</b>						
	#12 - 136, RBM - Right Hand Turnout						
	#12 - 136, RBM - Left Hand Turnout						
	<b>GUARD RAIL PACKS</b>						
	#12 - 136, RBM - Right Hand Turnout						
	#12 - 136, RBM - Left Hand Turnout						
	<b>SWITCH TIES</b>						
	9 ft (2.8 m)			25	25	25	25
	10 ft (3.1 m)			11	11	11	11
	11 ft (3.4 m)			8	8	8	8
	12 ft (3.7 m)			6	6	6	6
	13 ft (4.0 m)			10	10	10	10
	14 ft (4.3 m)			7	7	7	7
	15 ft (4.6 m)			8	8	8	8
	16 ft (4.9 m)			6	6	6	6