

- NOTE:
- TRANSITION TIES ARE FLAT SEAT DESIGN (NO CANT) REF. GTS-2106.
  - LABELS A, B & C AFFIXED TO TOP TIE IN EVERY BUNDLE ONLY.
  - TO AVOID VARIANCE IN RAIL GAUGE, DUE TO RAIL HEAD TO BASE ECCENTRICITY, ENSURE THAT THE RAIL BRAND OF ALL RAILS FACES IN THE SAME DIRECTION.
  - a. UNIFORM RISER PLATE THICKNESS:
    - 1/4" FOR TIES 2 TO 12
    - 3/16" FOR TIE 13
    - 1/8" FOR TIE 14
    - 1/16" FOR TIE 15
  - b. UNIFORM RISER PLATES SHALL CONFORM WITH LATEST ISSUES OF ASTM A36.
  - TIES WILL BE PUNCHED FOR 7/8" DIA. INSPECTION HOLES, LOCATION VARIES WITH RAIL POSITION.
  - POINT AND FROG AREA TIES ARE NARSTCO PATENTED INSULATED MULTI-STACK DESIGN. NARSTCO PATENT NO.7731099.
  - USE OFF-SET RAIL PADS IN RAIL SEATS FOR TIES WITH HOLES PUNCHED OFF CENTER, (TIES 18, 19, 45 & 56)
  - JOINT BARS SHOULD BE USED AS NECESSARY, JOINTS CAN BE WELDED TO PRODUCE CONTINUOUS RAIL IF REQUIRED.
  - ADJUSTABLE MJ CLIPS WITH VERTICAL SWITCH RODS SHOULD BE USED IN CHANNEL TIES.
  - TIES 60-70 ARE 15' OR OVER IN LENGTH.
  - TRANSITION TIES NOT INCLUDED IN TURNOUT PACKAGE.
  - IF ZERO POINT SWITCH POINTS ARE USED, A NOMINAL 3/8" WIDE GAUGE WILL OCCURE AT THE POINT OF SWITCH AND WILL TAPER BACK TO STANDARD GAUGE THROUGH THE SWITCH AREA BEFORE THE HEEL.
  - HEADBLOCK TIES ARE FIELD-DRILLED TO ACCEPT POWER OR MANUAL SWITCH STANDS.
  - Ⓢ -MECHANICAL JOINT LOCATIONS TO BE FIELD WELDED OR REMAIN AS STANDARD JOINTS AS DIRECTED BY METROLINX.
  - Ⓜ -INSULATED JOINT LOCATIONS TO BE INSTALLED WHEN TRACK CIRCUITS EXIST OR ARE REQUIRED AND SHALL BE THE CONTINUOUS GLUED TYPE WITH THE INSULATED JOINT UNDRILLED (BLANKED) RAIL ENDS FIELD WELDED.

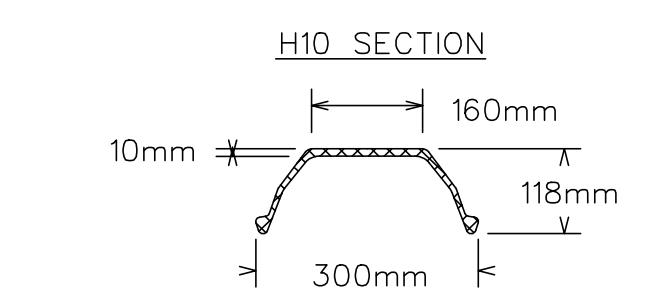

SECTION PROPERTIES  
 WEIGHT OF BAR: 30.8kg/m  
 YIELD STRENGTH: 345MPa (min)  
 SECTION MODUL II: Z TOP-153 X 10<sup>3</sup> mm<sup>3</sup>  
 : Z BOT-79.7 X 10<sup>3</sup> mm<sup>3</sup>

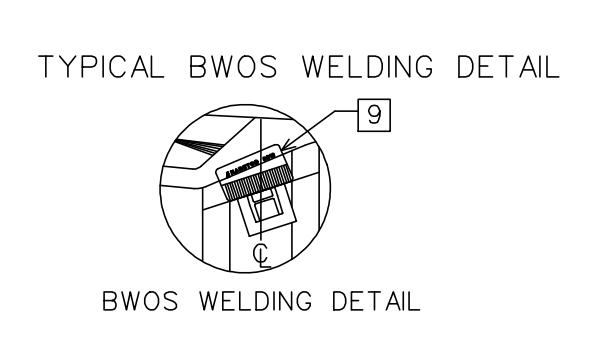

- IN PRACTICE:
- LOCATE 8017 FROG CLAMP AS SHOWN IN DETAIL
  - PLACE BWOS AGAINST FROG CLAMP ON TIE CENTER
  - TRACK WELD BWOS IN PLACE
  - USING 7018 WEELDING ROD, 3/16" OR BIGGER, PLACE 1/2" FILLET WELD ON OUTSIDE EDGES OF BWOS
  - DRIVE 8018 FROG CLAMP IN FROM RIGHTHAND SIDE
  - INSTALL SERRATED WASHER AND THEN CLIP
  - FOR MORE DETAILED INSTRUCTIONS, SEE S.O.P MG 045

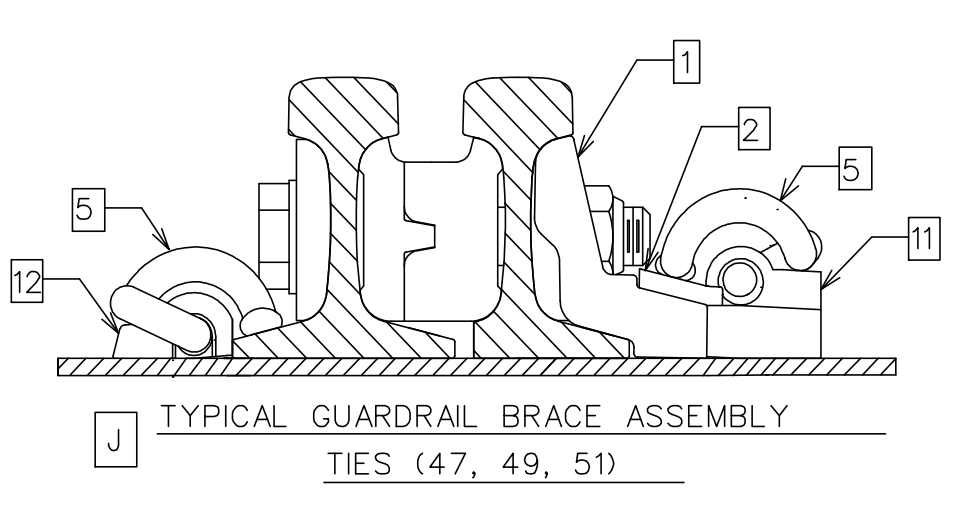
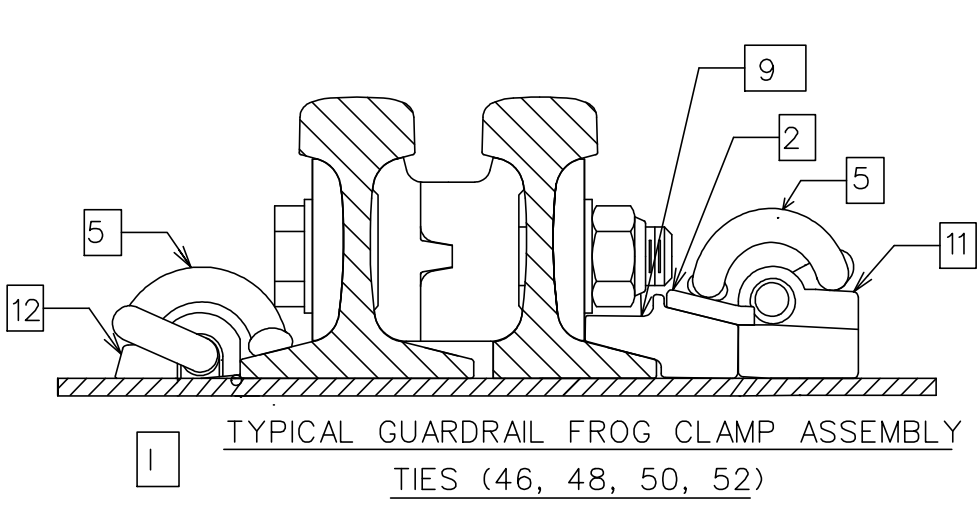

TURNOUT DATA		
FROG R.B.M.	NUMBER	10
	ANGLE	5°43'29"
SPREAD	TOE	6'7 1/2"
	HEEL	11'10"
	TOTAL	18'5 1/2"
TANGENT ADJACENT TO TOE OF FROG	TOE	7 7/16"
	HEEL	1'2 11/16"
SWITCH	TANGENT ADJACENT TO HEEL OF SWITCH	0"
	LENGTH	4'8 1/8"
	HEEL SPREAD	16'6"
	ANGLE	6 1/4"
	VERTEX DISTANCE	1°42'01"
TURNOUT	THROW	1'0 5/8"
	ACTUAL LEAD	4 3/4"
	CURVE ON CENTER LINE	81'6 1/2"
CLOSURE	DEGREE	7°44'25"
	RADIUS	740'9 1/2"
TRACK GAUGE	STRAIGHT	58'5"
	CURVED	58'6 13/16"
		4'8 1/2"

METRIC CONVERSION: 1 inch=25.4mm, 1 foot=304.8mm

0	18/12/23	DWG VERSION ESTABLISHED	
No.	Date	Revision	By Approved

Standard / GO TRANSIT #10-115lb INS CT PS  
 UNIFORM FXHL RBM 13' GUARD RAIL

Drawn MR. C Checked GWM Approved VP Engineering & Asset Management



Date DEC 23/2018 Plan Number GTS-2703 Rev 0

REFERENCE: Sheet 1 OF 1

## BILL OF MATERIALS FOR GTS-2703

ITEM	DESCRIPTION	NARSTCO PART NO.	QTY						
<b>TURNOUT COMPONENT</b>									
1	ADJUSTABLE RAIL BRACE	8014	18						
2	RAIL BRACE SERRATED WASHER	8015	44						
3#	RAIL BRACE HOOK-IN SHOULDER	8016	112						
4	NARSTCO HOOK-IN SHOULDER	4010	350						
5	'e' CLIP ('e' TYPE CLIP)	'e' CLIP	572						
6	WEDGE PLATE	14S,14T,15S, 15T,16S,16T, 17S, 17T	8						
7*	WEDGE PLATE PIN	14,15,16,17	8						
8	'J' CLIP	NJ1	32						
9	FROG CLAMP (R.B.M.)	8017	26						
10	L/H 'e' CLIP	Ne2	5						
11*	RAIL BRACE WELD-ON SHOULDER	BWOS	44						
12*	WELD-ON SHOULDER	WOS	58						
13	INSULATOR	HD-10	462						
14	OFFSET INSULATING PAD 5 1/2"	3020	12						
15	NARSTCO INSULATING PAD 5 1/2"	3025	162						
16	INSULATED JOINT INSULATOR	J7819	8						
17	INSULATED JOINT CLIP	e2063	8						
18	CUSTOM INSULATOR PAD	16,17,55	5						
19	JOINT BAR INSULATOR	N8J-HD	32						
<b>GO TRANSIT REFERENCES</b>									
<b>PLAN #</b>	<b>TITLE</b>								
GTS-0010-REV1	NO. 10 TURNOUT-115LB.RAIL 16'6" SAMSON POINT SWITCH UNIFORM RISER DESIGN WOOD TIES								
GTS-1125	GUARD RAILS TEE RAIL DESIGN WITH PLANED FLARES AND FLAT PLATES								
<b>VOESTALPINE NORTRAK REFERENCES</b>									
<b>PLAN #</b>	<b>TITLE</b>								
D10948	NO.10-115LB RBM FROG								
<b>FROG CLAMP (AFC) &amp; RAIL BRACE (ARB) LOCATION FOR GUARD RAILS</b>									
TIE NUMBER	45	46	47	48	49	50	51	52	53
THROUGH RAIL	AFC	ARB	AFC	AFC	ARB	AFC	ARB	ARB	AFC
TURNOUT RAIL	AFC	ARB	AFC	AFC	ARB	AFC	ARB	ARB	AFC
<b>LEGEND</b>									
* WELDED TO TIE DURING MANUFACTURING									
# INSTALLED ON TIE DURING MANUFACTURING									
^ TO BE INSTALLED ON SWITCH POINT PROTECTOR									