

ROD	POSITION FROM POINT OF SWITCH
1	1'-5"
2	3'-0"
3	6'-5"
4	11'-8"
5	16'-11"
6	22'-2"

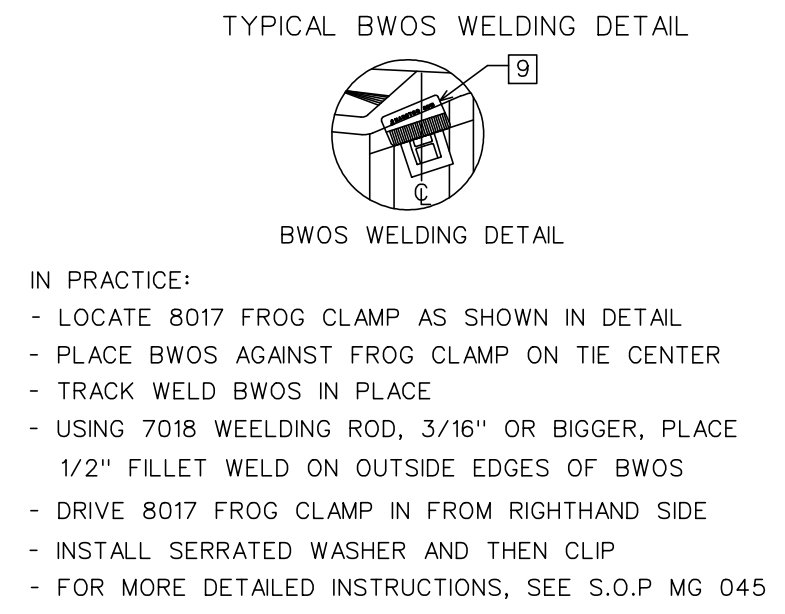
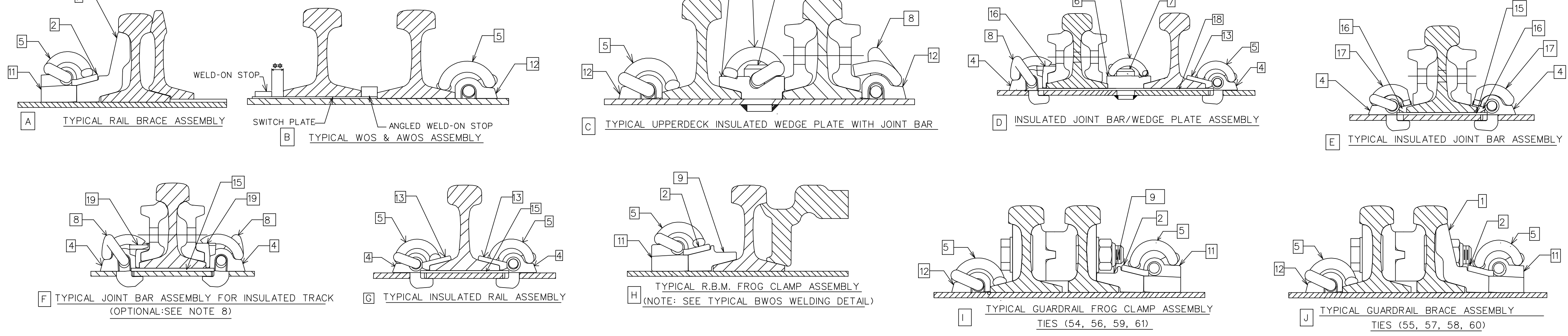

TIE BUNDLE LABEL FORMAT

A [NARSTCO 12 - 115]

1. TURNOUT NUMBER
2. RAIL WEIGHT

B [B1967 1 OF 1]

1. BATCH NO. FOR QUALITY ASSURANCE IDENTIFICATION
2. SEQUENTIAL NUMBER IN BATCH

C [JANUARY 2019]

1. MONTH PRODUCED
2. YEAR PRODUCED

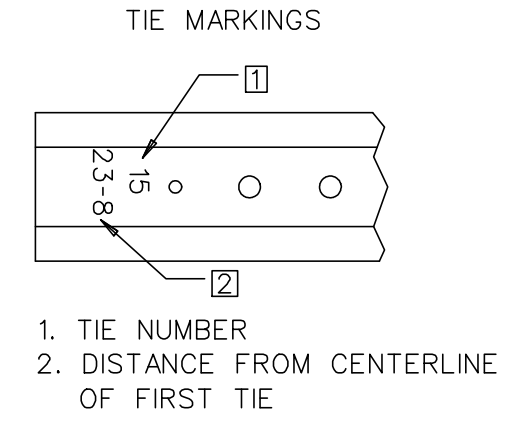

- NOTE:**
- TRANSITION TIES ARE FLAT SEAT DESIGN (NO CANT) REF. GTS-2106.
 - LABELS A, B & C AFFIXED TO TOP OF TIE IN EVERY BUNDLE ONLY.
 - TO AVOID VARIANCE IN RAIL GAUGE, DUE TO RAIL HEAD TO BASE ECCENTRICITY, ENSURE THAT THE RAIL BRAND OF ALL RAILS FACES IN THE SAME DIRECTION.
 - a. UNIFORM RISER PLATE THICKNESS:
 - 1/4" FOR TIES 2 TO 18
 - 3/16" FOR TIE 19
 - 1/8" FOR TIE 20
 - 1/16" FOR TIE 21
 - b. UNIFORM RISER PLATES SHALL CONFORM WITH LATEST ISSUES OF ASTM A36.
 - TIES WILL BE PUNCHED FOR 7/8" DIA. INSPECTION HOLES, LOCATION VARIES WITH RAIL POSITION.
 - POINT AND FROG AREA TIES ARE NARSTCO PATENTED INSULATED MULTI-STACK DESIGN. NARSTCO PATENT NO.7731099.
 - USE OFF-SET RAIL PADS IN RAIL SEATS FOR TIES WITH HOLES PUNCHED OFF CENTER, (TIES 23, 24, 52 & 66)
 - JOINT BARS SHOULD BE USED AS NECESSARY, JOINTS CAN BE WELDED TO PRODUCE CONTINUOUS RAIL IF REQUIRED.
 - ADJUSTABLE MJ CLIPS WITH VERTICAL SWITCH RODS SHOULD BE USED IN CHANNEL TIES.
 - HEELS ARE FLOATING AND POINTS ARE EXTENDED POINT LENGTHS ARE 36'5"
 - WELD ON STOPS ARE USED ON THE FOLLOWING TIES FOR POINT FLEX (SEE DETAIL B):
 - ***3/4" FOR TIE 19
 - TIES 71-82 ARE 15' OR OVER IN LENGTH.
 - TRANSITION TIES NOT INCLUDED IN TURNOUT PACKAGE.
 - HEADBLOCK TIES ARE FIELD-DRILLED TO ACCEPT POWER OR MANUAL SWITCH STANDS.
 - ⊕ -MECHANICAL JOINT LOCATIONS TO BE FIELD WELDED OR REMAIN AS STANDARD JOINTS AS DIRECTED BY METROLINX.
 - ⊞ -INSULATED JOINT LOCATIONS TO BE INSTALLED WHEN TRACK CIRCUITS EXIST OR ARE REQUIRED AND SHALL BE THE CONTINUOUS GLUED TYPE WITH THE INSULATED JOINT UNDRILLED (BLANKED) RAIL ENDS FIELD WELDED.

TURNOUT DATA		
FROG R.B.M.	NUMBER	12
	ANGLE	4°46'19"
	LENGTH	TOE: 14'3" HEEL: 17'3" TOTAL: 31'6"
SPREAD	TOE	1'1 35/64"
	HEEL	1'5 25/32"
SWITCH	LENGTH	27'4 1/16"
	HEEL SPREAD	6 1/4"
	ANGLE	0°26'15"
	VERTEX DISTANCE	0"
	THROW	4 3/4"
TURNOUT	ACTUAL LEAD	98'1"
	CURVE ON CENTER LINE	DEGREE: 4°47'39" RADIUS: 1195.45'
	CLOSURE LENGTH	STRAIGHT: 56'5 15/16" CURVED: 56'7 7/16"
ACTUAL LENGTH	STRAIGHT	47'5"
	CURVED	47'6 1/2"
TRACK GAUGE		4'8 1/2"

METRIC CONVERSION: 1 inch=25.4mm, 1 foot=304.8mm

No.	Date	Revision	By	Approved
0	19/03/15	DWG VERSION ESTABLISHED		

Standard / **GO TRANSIT #12-115b INS CT PS UNIFORM FLHL RBM 13' GUARD RAIL**

Drawn MR. C Checked GWM Approved VP Engineering & Asset Management

Date MAR 15/2019 Plan Number GTS-2713 Rev 0

REFERENCE: NARSTCO 2713 Sheet 1 OF 1

BILL OF MATERIALS FOR GTS-2713

ITEM	DESCRIPTION	NARSTCO PART NO.	QTY					
TURNOUT COMPONENT								
1	ADJUSTABLE RAIL BRACE	8014	20					
2	RAIL BRACE SERRATED WASHER	8015	46					
3#	RAIL BRACE HOOK-IN SHOULDER	8016	120					
4	NARSTCO HOOK-IN SHOULDER	4010	398					
5	'e' CLIP ('e' TYPE CLIP)	'e' CLIP	644					
6	JOINT WEDGE PLATE	20S, 20T, 21S, 21T, 22S, 22T	6					
7*	WEDGE PLATE PIN	20, 21, 22	6					
8	'J' CLIP	NJ1	32					
9	FROG CLAMP (R.B.M.)	8017	26					
10	L/H 'e' CLIP	Ne2	5					
11*	RAIL BRACE WELD-ON SHOULDER	BWOS	46					
12*	WELD-ON SHOULDER	WOS	74					
13	INSULATOR	HD-10	518					
14	OFFSET INSULATING PAD 5 1/2"	3020	12					
15	NARSTCO INSULATING PAD 5 1/2"	IN-0030	182					
16	INSULATED JOINT INSULATOR	J7819	8					
17	INSULATED JOINT CLIP	e2063	8					
18	CUSTOM INSULATOR PAD	22, 53, 64, 65	5					
19	JOINT BAR INSULATOR	N8J-HD	32					
GO TRANSIT REFERENCES								
PLAN #	TITLE							
GTS-0003A-REV1	GEOMETRY FOR NO. 12 ALL WELDED TURNOUTS							
GTS-0284-REV1	NO.12 TURNOUT - 36'-5" POWER OPERATED - SAMSON POINT SWITCH - UNIFORM RISER DESIGN - ALL WELDED RAIL - RBM FROG - 115 LB RE RAIL - WOOD TIES							
GTS-0886-REV1	ASSEMBLY - NO.12 LOW IMPACT HEEL RBM FROG - 136 LB. R.E. RAILS							
GTS-1125	GUARD RAILS TEE RAIL DESIGN WITH PLANED FLARES AND FLAT PLATES							
FROG CLAMP (AFC) & RAIL BRACE (ARB) LOCATION FOR GUARD RAILS								
TIE NUMBER	54	55	56	57	58	59	60	61
THROUGH RAIL	AFC	ARB	AFC	ARB	ARB	AFC	ARB	AFC
TURNOUT RAIL	AFC	ARB	AFC	ARB	ARB	AFC	ARB	AFC
LEGEND								
* WELDED TO TIE DURING MANUFACTURING								
# INSTALLED ON TIE DURING MANUFACTURING								