

ASSEMBLY DETAILS - STRAIGHT SAMSON POINT RAIL

RIGHT POINT RAIL FOR R.H. TURNOUT - GTS 0379 D (ILLUSTRATED)
LEFT POINT RAIL FOR L.H. TURNOUT - GTS 0379 C

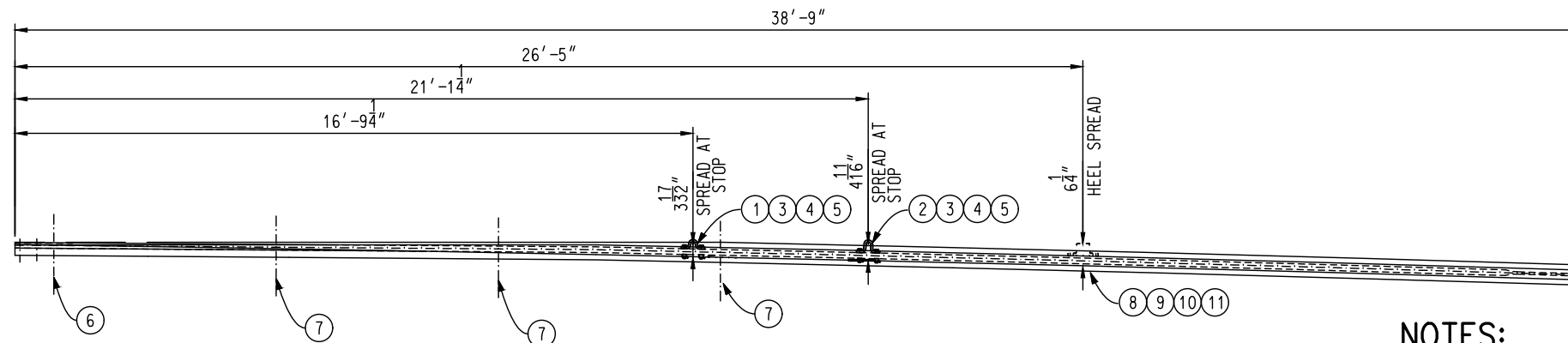

ASSEMBLY DETAILS - CURVED SAMSON POINT RAIL

RIGHT POINT RAIL FOR L.H. TURNOUT - GTS 0379 A (ILLUSTRATED)
LEFT POINT RAIL FOR R.H. TURNOUT - GTS 0379 B

NOTES:

- SWITCH CLIPS ARE NOT INCLUDED IN SWITCH POINT ASSEMBLY AND MUST BE ORDERED SEPARATELY IF REQUIRED.
- WHEN REFERRING TO POINT RAILS, DRAWING NUMBER MUST BE STATED AS A, B, C OR D TO INDICATE SPECIFIC POINT REQUIRED.

POINT ASSEMBLY INCLUDES:

ITEM NO.	DESCRIPTION	STANDARD PLAN NO.	QUANTITY DWG. No. GTS-0379
1	POINT STOP 339 N	GTS-0339N	1
2	POINT STOP 339 M	GTS-0339M	1
3	BOLT 3/4" X 4-1/4" C/W SQ. NUT	GTS-1305/9	4
4	SPRING WASHER 3/4"	GTS-1301	4
5	COTTER PIN 3/16" X 1-1/4"	-----	4

NOTE: THE FOLLOWING ITEMS ARE NOT INCLUDED IN THE SWITCH POINT ASSEMBLY AND MUST BE ORDERED SEPARATELY IF REQUIRED.

ITEM NO.	DESCRIPTION	STANDARD PLAN NO.	QUANTITY DWG. No. GTS-0379
6	ROCKER CLIP ASSEMBLY (352/L)	GTS-0352/L	1
7	ROCKER CLIP ASSEMBLY (352/M)	GTS-0352/M	3
8	HEEL BLOCK GO 383 TW	GTS-0383	1
9	1-1/8" X 5-1/2" BOLT - 7 UNC	GTS-1308/10	2
10	SPRING WASHER FOR 1-1/8" BOLT	GTS-1301	2
11	LOCKNUT FOR 1-1/8" BOLT - 7 UNC	GTS-1302	2

METRIC CONVERSION: 1 inch=25.4mm, 1 foot=304.8mm

No.	Date	Revision	By	Approved
1	18/07/27	ADDED IMPERIAL TO METRIC CONVERSION NOTE		

Standard / **ASSEMBLY-UNIFORM RISER DESIGN**
38'9" SAMSON POINT RAIL-THICK WEB
NO. 16 ALL WELDED TURNOUT
MANUAL SPRING & POWER OPERATED-136 RAIL

Drawn MG Checked RP Approved *[Signature]*
VP Engineering & Asset Management



Date SEPT 15/2017 Plan Number GTS-0379 Rev 1