

FROG PLATE.

PLATES	A ±1/16	B ±1/32	C ±1/32	D ±1/32	E ±1/32	WEIGHT (LBS.)	REPLACED BY	
							MARK No.	GTS DWG.
FP-796L	36-1/2	12	12-1/2	12-17/32	11-31/32	71.0		
FP-797L	37-1/2	12-3/32	13-13/32	13-3/32	11-15/16	72.0		
FP-798L	41	12-3/32	16-29/32	13-3/32	15-7/16	78.0		
FP-800L	43-1/2	12-3/32	19-13/32	12-19/32	18-29/32	82.0		
FP-801L	41	12	16-27/32	13	15-13/32	78.0		
FP-802L	41-1/4	12-1/32	17-7/32	12-19/32	16-21/32	79.0		
FP-803L	42-1/2	12-1/32	18-15/32	12-9/16	17-15/16	81.0		
FP-804L	43-3/4	12	19-3/4	12-17/32	19-7/32	83.0		

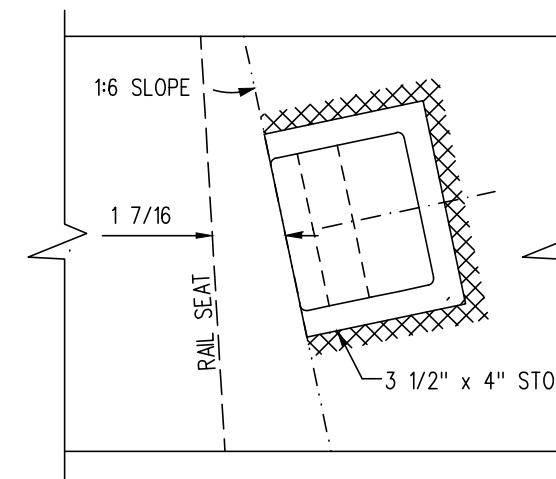

TYPICAL SHOULDER INSTALLATION

NOTES

1. WHEN REFERRING TO FROG PLATES, PLAN AND PLATE NUMBERS MUST BE STATED TO INDICATE SPECIFIC PLATE REQUIRED.
2. IDENTIFICATION CHARACTERS (1/2" MINIMUM HEIGHT) TO BE STAMPED ON EACH PLATE AS SHOWN.
3. ALL DIMENSIONS ARE IN INCHES.
4. UNLESS OTHERWISE SPECIFIED ALL TOLERANCES TO BE ±1/32.
5. TOLERANCES ARE NOT TO EXCEED THOSE INDICATED IN THE GO TOLERANCE DRAWINGS.
6. PLATE TO BE PAINTED WITH INSULATION PAINT ON 5 SIDES OF END AS SHOWN

MATERIAL

PLATES TO CONFORM TO THE LATEST REVISION OF A.S.T.M. SPECIFICATION A-36 FOR COMMERCIAL QUALITY HOT ROLLED BAR STEEL CHEMICAL REQUIREMENT.

	MINIMUM	MAXIMUM
CARBON	0.25 %	0.29 %
MANGANESE	0.60 %	1.20 %
PHOSPHORUS		0.04 %
SULPHUR		0.05 %
SILICON		0.40 %

0	17/09/15	DWG VERSION ESTABLISHED	
No.	Date	Revision	By Approved
Standard/		FROG PLATES LEFT HAND	
Drawn	PCV	Checked	DL
		Approved	<i>[Signature]</i> VP Corridor Infrastructure
Date	SEPT 15/2017	Plan Number	GTS-0694
		Rev	0
REFERENCE: TS-0694_SH2_R0		Sheet 2 OF 4	