

SIGN BLANKS

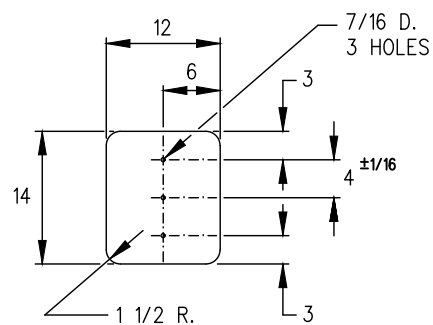

RECTANGLE
(12 X 14)
WT.: 1.32 LB.

MANUFACTURING DETAILS

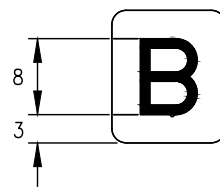

BACKGROUND : REFLECTIVE YELLOW
SYMBOL :SILK SCREENED BLACK OR VINYL SHEETING
"B" SYMBOL TO BE OF "STANDARD MEDIUM" ALPHABET.

BLOCK CLEARANCE POINT SIGN

LOCATION

BLOCK CLEARANCE POINT SIGNS ARE TO BE LOCATED OPPOSITE THE INSULATED JOINT AND/OR IMMEDIATELY BEYOND THE CLEARANCE POINT OF THE SIDING IN BLOCK SIGNAL TERRITORY ONLY.

NOTES :

GENERAL :

1. WHEN REQUISITIONING SIGNS, QUANTITY, STOCK NUMBER AND CHARACTERISTICS (WHEN REQUIRED) MUST BE INDICATED ON REQUISITION. HARDWARE MUST ALSO BE ORDERED ACCORDING TO ILLUSTRATIONS SHOWING THE NUMBER OF BOLT HOLES PER SIGN.
2. FULL SIZE SIGN TEMPLATES AVAILABLE UPON REQUEST.

MATERIALS:

1. SIGN BLANKS TO BE ALUMINUM SHEET, ALLOY 3003, H14 (12 GA.) MILL FINISH.
2. REFLECTIVE SHEETING MUST CONFORM TO THE LATEST ISSUE OF CANADIAN GENERAL STANDARDS BOARD (CGSB) STANDARD 62-GP-11 M, LEVEL 1 MATERIAL.
3. VINYL SHEETING MUST CONFORM TO THE LATEST ISSUE OF CANADIAN GENERAL STANDARDS BOARD (CGSB) STANDARD 62-GP- 3M MATERIAL.

MANUFACTURING :

1. UNLESS OTHERWISE STATED, COLOR SHEETING AND SYMBOLS ARE APPLIED ON ONE SIDE ONLY.
2. ALL DIMENSIONS ARE IN INCHES.
3. ALL HOLES TO BE PUNCHED OR DRILLED.
4. ALUMINUM UNPAINTED SURFACE MUST BE THOROUGHLY DEGREASED, ETCHED, AND RINSED.
5. SHEETING TO BE APPLIED DIRECTLY TO THE PREPARED ALUMINUM SURFACE.

ERECTION :

1. UNLESS OTHERWISE INDICATED IN THE DESCRIPTION OF LOCATING AND ERECTING REMARKS:
 - A.- ALL SIGNS SHALL BE ERECTED AT RIGHT ANGLES TO TRACK WHICH THEY GOVERN.
 - B.-WHEN ERECTING SIGNS ON TWO (OR MORE) TRACKS AND EACH TRACK HAS DOUBLE DIRECTION TRAFFIC, SIGNS ARE TO LOCATED ON THE FIELD SIDE OF EACH EXTREME OUGTSIDE TRACK.
 - C.- ALL SIGNS SHALL BE ERECTED 10 TO 25 FEET FROM THE GAUGE SIDE OF THE NEAREST RAIL TO THE RIGHT OF THE TRACK AS VIEWED FROM AN APPROACHING TRAIN. IN RESTRICTED SIDE CLEARANCE AREAS, THE MINIMUM DISTANCE OF 6 FEET FROM GAUGE SIDE OF THE NEAREST RAIL TO ANY PORTION OF THE SIGN MUST BE MET WITH CONSIDERATION GIVEN TO CURVED AND SUPERELEVATED FEATURES.
 - D.- ALL SIGNS SHALL BE AT A MINIMUM OF 8 FEET FROM TOP OF RAIL TO THE CENTRE LINE OF THE LOWEST SIGN ON THE POST.
 - E.- ALL SIGNS SHALL BE MOUNTED ON THE STANDARD " U " POST FOR TRACK SIGNS, UNLESS OTHERWISE SPECIFIED.
 - F.- ALL POSTS MUST PENETRATE GROUND A MINIMUM OF 4 FEET.
2. ALL SIGNS SHALL BE LOCATED AND ERECTED IN A MANNER THAT WILL AFFORD THE MOST ADVANTAGEOUS VIEW FROM AN APPROACHING TRAIN.

ITEM NO.	DESCRIPTION	PLAN NUMBER
1	KIT SIGN MOUNTING ASSEMBLY	GTS-0720
2	SIGN (STATE TYPE AND STOCK NUMBER)	GTS-0719
3	" U " POST FOR TRACK SIGNS	GTS-0719
4	BLOCK FILLER FOR POST (CAST OR FORMED)	---
5	FIBRE WASHER 3/8 I.D. x 5/8 O.D. x 1/16 THICK	---
6	3/8 DIA.-16 UNC RD. CAP SCREW 2-1/2 LG. C/W SQ. NUT	---
7	SPRING WASHER HELICAL FOR 3/8 CAP SCREW, PLATED	---
	PLATE WASHER 7/16 I.D. x 1 O.D. x 5/64 THICK, PLATED	---

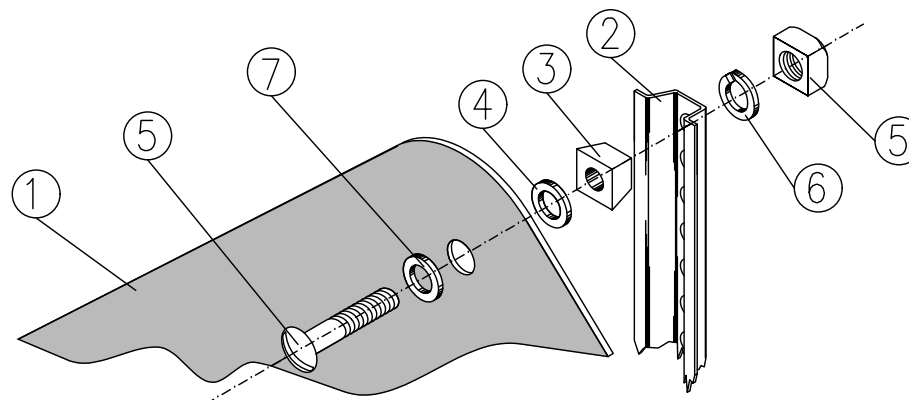

0	17/09/15	DWG VERSION ESTABLISHED	
No.	Date	Revision	By Approved
Standard/		SIGNS	
Drawn	MG	Checked	GGS
		Approved	<i>MBLL</i> VP Corridor Infrastructure
		METROLINX	
Date	SEPT 15/2017	Plan Number	GTS-0720
		Rev	0
REFERENCE: TS-0720_SH6_R3		Sheet 6 OF 41	

FOR ADDITIONAL INFORMATION E-MAIL "TRACKSTD"