

SIGN BLANKS

MANUFACTURING DETAILS

LOCATION

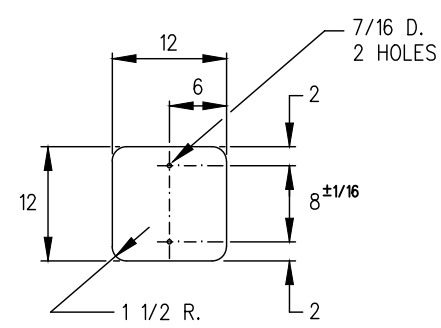

RECTANGLE
(12 X 12)
WT.:_1.13_LB

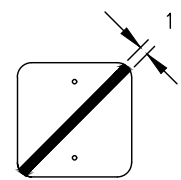

RESTRICTING SPEED
SIGN

FRONT VIEW

BACKGROUND: REFLECTIVE YELLOW
SLASH: SILK SCREENED BLACK
OR VINYL SHEETING

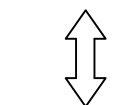

RESUME SPEED
SIGN

BACK VIEW

BACKGROUND: REFLECTIVE GREEN

RESTRICTING SPEED SIGNS WILL BE PLACED AT THE BEGINNING OF PERMANENT SLOW ORDERS.

RESUME SPEED SIGNS WILL BE PLACED AS FOLLOWS:
- SINGLE TRACK- THE REVERSE SIDE OF THE RESTRICTING SIGN WILL INDICATE END OF PERMANENT SLOW ORDER.
- MULTITRACK- SIGNS WILL BE PLACED TO INDICATE END OF PERMANENT SLOW ORDER.

NOTES :

GENERAL :

1. WHEN REQUISITIONING SIGNS, QUANTITY, STOCK NUMBER AND CHARACTERISTICS (WHEN REQUIRED) MUST BE INDICATED ON REQUISITION. HARDWARE MUST ALSO BE ORDERED ACCORDING TO ILLUSTRATIONS SHOWING THE NUMBER OF BOLT HOLES PER SIGN.
2. FULL SIZE SIGN TEMPLATES AVAILABLE UPON REQUEST.

MATERIALS:

1. SIGN BLANKS TO BE ALUMINUM SHEET, ALLOY 3003, H14 (12 GA.) MILL FINISH.
2. REFLECTIVE SHEETING MUST CONFORM TO THE LATEST ISSUE OF CANADIAN GENERAL STANDARDS BOARD (CGSB) STANDARD 62-GP-11 M, LEVEL 1 MATERIAL.
3. VINYL SHEETING MUST CONFORM TO THE LATEST ISSUE OF CANADIAN GENERAL STANDARDS BOARD (CGSB) STANDARD 62-GP- 3M MATERIAL.

MANUFACTURING :

1. UNLESS OTHERWISE STATED, COLOR SHEETING AND SYMBOLS ARE APPLIED ON ONE SIDE ONLY.
2. ALL DIMENSIONS ARE IN INCHES.
3. ALL HOLES TO BE PUNCHED OR DRILLED.
4. ALUMINUM UNPAINTED SURFACE MUST BE THOROUGHLY DEGREASED, ETCHED, AND RINSED.
5. SHEETING TO BE APPLIED DIRECTLY TO THE PREPARED ALUMINUM SURFACE.

ERECTION :

1. UNLESS OTHERWISE INDICATED IN THE DESCRIPTION OF LOCATING AND ERECTING REMARKS:
 - A.- ALL SIGNS SHALL BE ERECTED AT RIGHT ANGLES TO TRACK WHICH THEY GOVERN.
 - B.-WHEN ERECTING SIGNS ON TWO (OR MORE) TRACKS AND EACH TRACK HAS DOUBLE DIRECTION TRAFFIC, SIGNS ARE TO LOCATED ON THE FIELD SIDE OF EACH EXTREME OUTSIDE TRACK.
 - C.- ALL SIGNS SHALL BE ERECTED 10 TO 25 FEET FROM THE GAUGE SIDE OF THE NEAREST RAIL TO THE RIGHT OF THE TRACK AS VIEWED FROM AN APPROACHING TRAIN. IN RESTRICTED SIDE CLEARANCE AREAS, THE MINIMUM DISTANCE OF 6 FEET FROM GAUGE SIDE OF THE NEAREST RAIL TO ANY PORTION OF THE SIGN MUST BE MET WITH CONSIDERATION GIVEN TO CURVED AND SUPERELEVATED FEATURES.
 - D.- ALL SIGNS SHALL BE AT A MINIMUM OF 8 FEET FROM TOP OF RAIL TO THE CENTRE LINE OF THE LOWEST SIGN ON THE POST.
 - E.- ALL SIGNS SHALL BE MOUNTED ON THE STANDARD " U " POST FOR TRACK SIGNS, UNLESS OTHERWISE SPECIFIED.
 - F.- ALL POSTS MUST PENETRATE GROUND A MINIMUM OF 4 FEET.
2. ALL SIGNS SHALL BE LOCATED AND ERECTED IN A MANNER THAT WILL AFFORD THE MOST ADVANTAGEOUS VIEW FROM AN APPROACHING TRAIN.

ITEM NO.	DESCRIPTION	PLAN NUMBER
1	KIT SIGN MOUNTING ASSEMBLY	
1	SIGN (STATE TYPE AND STOCK NUMBER)	GTS-0720
2	" U " POST FOR TRACK SIGNS	GTS-0719
3	BLOCK FILLER FOR POST (CAST OR FORMED)	GTS-0719
4	FIBRE WASHER 3/8 I.D. x 5/8 O.D. x 1/16 THICK	—
5	3/8 DIA.-16 UNC RD. CAP SCREW 2-1/2 LG. C/W SQ. NUT	—
6	SPRING WASHER HELICAL FOR 3/8 CAP SCREW, PLATED	—
7	PLATE WASHER 7/16 I.D. x 1 O.D. x 5/64 THICK, PLATED	—

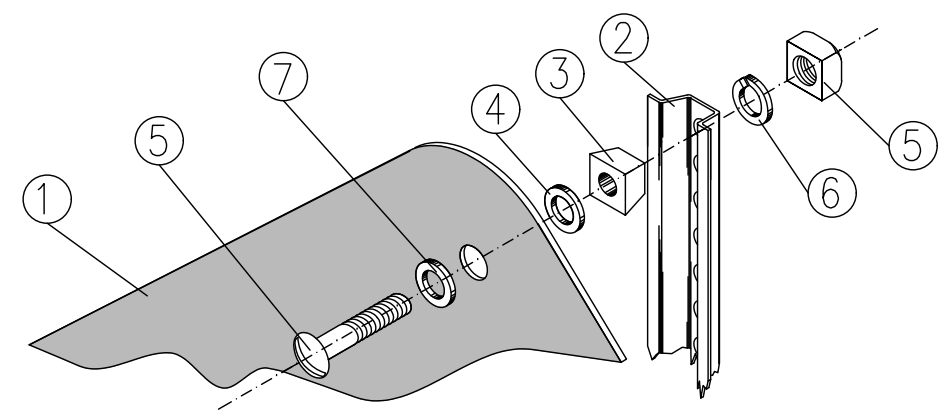

METRIC CONVERSION: 1 inch=25.4mm, 1 foot=304.8mm

No.	Date	Revision	By Approved
1	18/07/27	ADDED IMPERIAL TO METRIC CONVERSION NOTE	
Standard/		SIGNS	
Drawn	Checked	Approved	
MG	GGS	<i>[Signature]</i>	VP Engineering & Asset Management
Date	SEPT 15/2017	Plan Number	GTS-0720 Rev 1
REFERENCE: TS-0720_SH19_R3		Sheet 19 OF 41	