

SIGN BLANKS

MANUFACTURING DETAILS

LOCATION

NOTES :

GENERAL :

1. WHEN REQUISITIONING SIGNS, QUANTITY, STOCK NUMBER AND CHARACTERISTICS (WHEN REQUIRED) MUST BE INDICATED ON REQUISITION. HARDWARE MUST ALSO BE ORDERED ACCORDING TO ILLUSTRATIONS SHOWING THE NUMBER OF BOLT HOLES PER SIGN.
2. FULL SIZE SIGN TEMPLATES AVAILABLE UPON REQUEST.

MATERIALS:

1. SIGN BLANKS TO BE ALUMINUM SHEET, ALLOY 3003, H14 (12 GA.) MILL FINISH.
2. REFLECTIVE SHEETING MUST CONFORM TO THE LATEST ISSUE OF CANADIAN GENERAL STANDARDS BOARD (CGSB) STANDARD 62-GP-11 M, LEVEL 1 MATERIAL.
3. VINYL SHEETING MUST CONFORM TO THE LATEST ISSUE OF CANADIAN GENERAL STANDARDS BOARD (CGSB) STANDARD 62-GP- 3M MATERIAL.

MANUFACTURING :

1. UNLESS OTHERWISE STATED, COLOR SHEETING AND SYMBOLS ARE APPLIED ON ONE SIDE ONLY.
2. ALL DIMENSIONS ARE IN INCHES.
3. ALL HOLES TO BE PUNCHED OR DRILLED.
4. ALUMINUM UNPAINTED SURFACE MUST BE THOROUGHLY DEGREASED, ETCHED, AND RINSED.
5. SHEETING TO BE APPLIED DIRECTLY TO THE PREPARED ALUMINUM SURFACE.

ERECTION :

1. UNLESS OTHERWISE INDICATED IN THE DESCRIPTION OF LOCATING AND ERECTING REMARKS:
 - A.- ALL SIGNS SHALL BE ERECTED AT RIGHT ANGLES TO TRACK WHICH THEY GOVERN.
 - B.-WHEN ERECTING SIGNS ON TWO (OR MORE) TRACKS AND EACH TRACK HAS DOUBLE DIRECTION TRAFFIC, SIGNS ARE TO LOCATED ON THE FIELD SIDE OF EACH EXTREME OUTSIDE TRACK.
 - C.- ALL SIGNS SHALL BE ERECTED 10 TO 25 FEET FROM THE GAUGE SIDE OF THE NEAREST RAIL TO THE RIGHT OF THE TRACK AS VIEWED FROM AN APPROACHING TRAIN. IN RESTRICTED SIDE CLEARANCE AREAS, THE MINIMUM DISTANCE OF 6 FEET FROM GAUGE SIDE OF THE NEAREST RAIL TO ANY PORTION OF THE SIGN MUST BE MET WITH CONSIDERATION GIVEN TO CURVED AND SUPERELEVATED FEATURES.
 - D.- ALL SIGNS SHALL BE AT A MINIMUM OF 8 FEET FROM TOP OF RAIL TO THE CENTRE LINE OF THE LOWEST SIGN ON THE POST.
 - E.- ALL SIGNS SHALL BE MOUNTED ON THE STANDARD " U " POST FOR TRACK SIGNS, UNLESS OTHERWISE SPECIFIED.
 - F.- ALL POSTS MUST PENETRATE GROUND A MINIMUM OF 4 FEET.
2. ALL SIGNS SHALL BE LOCATED AND ERECTED IN A MANNER THAT WILL AFFORD THE MOST ADVANTAGEOUS VIEW FROM AN APPROACHING TRAIN.

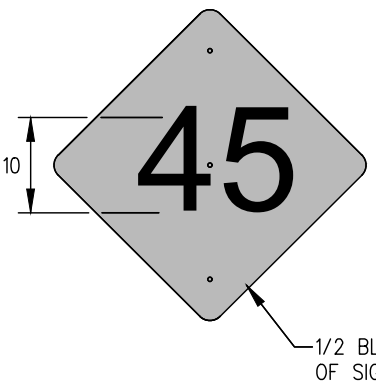
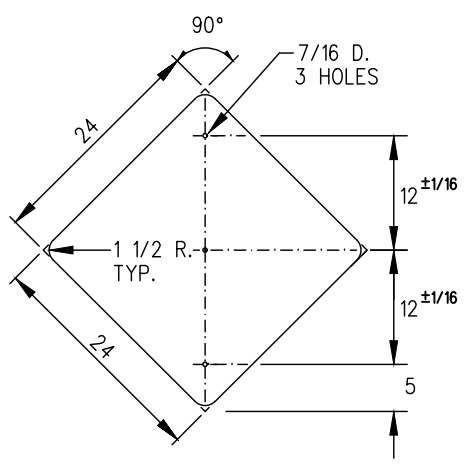

BACKGROUND: REFLECTIVE YELLOW (BOTH SIDES)
 NUMBERS: SILK SCREENED BLACK OR VINYL SHEETING
 NUMBERS TO BE OF "STANDARD MEDIUM" ALPHABET.

INCREASING ZONE SPEED SIGNS INDICATE AN INCREASE IN ZONE SPEED AND WILL BE PLACED AT THE BEGINNING OF THE SPEED ZONE TO INDICATE MAXIMUM ALLOWABLE SPEED WITHIN THE LIMITS OF THE OF THE ZONE IDENTIFIED IN THE TIME TABLE.

- SIGN WILL NOT BE PLACED:
- IN TERMINALS
 - ON SUBDIVISIONS WHICH HAVE ONE SPEED ZONE.
 - ON SUBDIVISIONS WITH A MAXIMUM SPEED OF 30 MPH OR LESS.

DIAMOND
 WT.: 4.52 LB

INCREASING ZONE SPEED SIGN
 (SINGLE SPEED)
 TYPE 1

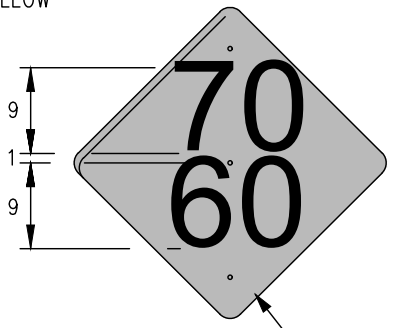
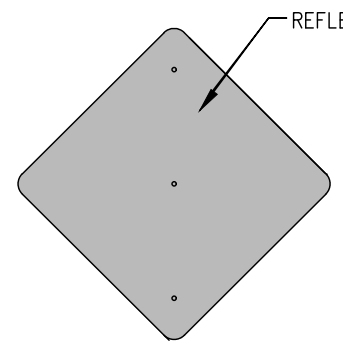

BACKGROUND: REFLECTIVE YELLOW (BOTH SIDES)
 NUMBERS: SILK SCREENED BLACK OR VINYL SHEETING
 NUMBERS TO BE OF "STANDARD MEDIUM" ALPHABET.

INCREASING ZONE SPEED SIGNS INDICATE AN INCREASE IN ZONE SPEED AND WILL BE PLACED AT THE BEGINNING OF THE SPEED ZONE TO INDICATE MAXIMUM ALLOWABLE SPEED WITHIN THE LIMITS OF THE OF THE ZONE IDENTIFIED IN THE TIME TABLE.

- SIGN WILL NOT BE PLACED:
- IN TERMINALS
 - ON SUBDIVISIONS WHICH HAVE ONE SPEED ZONE.
 - ON SUBDIVISIONS WITH A MAXIMUM SPEED OF 30 MPH OR LESS.

BACK OF SIGN

INCREASING ZONE SPEED SIGN
 (DUAL SPEEDS)
 TYPE 2

ITEM NO.	DESCRIPTION	PLAN NUMBER
1	KIT SIGN MOUNTING ASSEMBLY	
1	SIGN (STATE TYPE AND STOCK NUMBER)	GTS-0720
2	" U " POST FOR TRACK SIGNS	GTS-0719
3	BLOCK FILLER FOR POST (CAST OR FORMED)	GTS-0719
4	FIBRE WASHER 3/8 I.D. x 5/8 O.D. x 1/16 THICK	—
5	3/8 DIA.-16 UNC RD. CAP SCREW 2-1/2 LG. C/W SQ. NUT	—
6	SPRING WASHER HELICAL FOR 3/8 CAP SCREW, PLATED	—
7	PLATE WASHER 7/16 I.D. x 1 O.D. x 5/64 THICK, PLATED	—

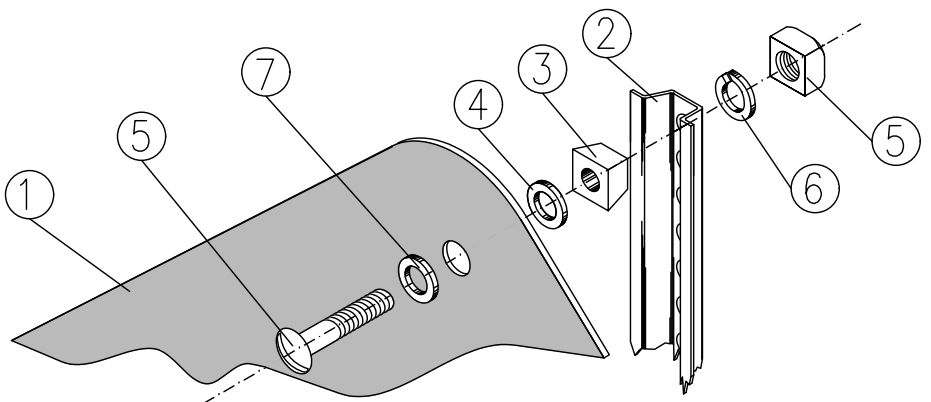

METRIC CONVERSION: 1 inch=25.4mm, 1 foot=304.8mm

1	18/07/27	ADDED IMPERIAL TO METRIC CONVERSION NOTE	
No.	Date	Revision	By Approved

Standard/ **SIGNS**

Drawn MG Checked GGS Approved *[Signature]*
 VP Engineering & Asset Management



Date SEPT 15/2017 Plan Number GTS-0720 Rev 1