

SIGN BLANKS

MANUFACTURING DETAILS

LOCATION

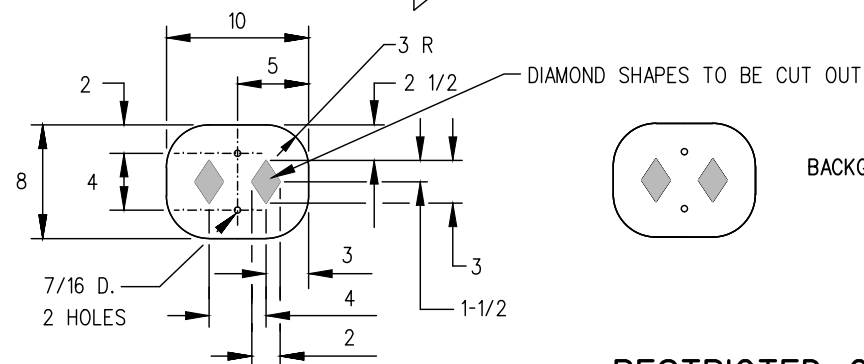

RECTANGLE (10_X_8)
WT.: 0.56 LB.



RESTRICTED CLEARANCE SIGN

RESTRICTED CLEARANCE SIGNS ARE TO BE LOCATED AS DIRECTED BY THE DISTRICT ENGINEER IN ACCORDANCE WITH STANDARD RESPECTING RAILWAY CLEARANCES APPENDIX "A" CLAUSE 4.4 LATEST DATE. WHERE SPACE DOES NOT PERMIT INSTALLATION OF CONVENTIONAL POST, A BRACKET MAY BE USED TO MOUNT SIGN ON ADJACENT BUILDING OR STRUCTURE.

NOTES :

GENERAL :

1. WHEN REQUISITIONING SIGNS, QUANTITY, STOCK NUMBER AND CHARACTERISTICS (WHEN REQUIRED) MUST BE INDICATED ON REQUISITION. HARDWARE MUST ALSO BE ORDERED ACCORDING TO ILLUSTRATIONS SHOWING THE NUMBER OF BOLT HOLES PER SIGN.
2. FULL SIZE SIGN TEMPLATES AVAILABLE UPON REQUEST.

MATERIALS:

1. SIGN BLANKS TO BE ALUMINUM SHEET, ALLOY 3003, H14 (12 GA.) MILL FINISH.
2. REFLECTIVE SHEETING MUST CONFORM TO THE LATEST ISSUE OF CANADIAN GENERAL STANDARDS BOARD (CGSB) STANDARD 62-GP-11 M, LEVEL 1 MATERIAL.
3. VINYL SHEETING MUST CONFORM TO THE LATEST ISSUE OF CANADIAN GENERAL STANDARDS BOARD (CGSB) STANDARD 62-GP- 3M MATERIAL.

MANUFACTURING :

1. UNLESS OTHERWISE STATED, COLOR SHEETING AND SYMBOLS ARE APPLIED ON ONE SIDE ONLY.
2. ALL DIMENSIONS ARE IN INCHES.
3. ALL HOLES TO BE PUNCHED OR DRILLED.
4. ALUMINUM UNPAINTED SURFACE MUST BE THOROUGHLY DEGREASED, ETCHED, AND RINSED.
5. SHEETING TO BE APPLIED DIRECTLY TO THE PREPARED ALUMINUM SURFACE.

ERECTION :

1. UNLESS OTHERWISE INDICATED IN THE DESCRIPTION OF LOCATING AND ERECTING REMARKS:
 - A.- ALL SIGNS SHALL BE ERECTED AT RIGHT ANGLES TO TRACK WHICH THEY GOVERN.
 - B.-WHEN ERECTING SIGNS ON TWO (OR MORE) TRACKS AND EACH TRACK HAS DOUBLE DIRECTION TRAFFIC, SIGNS ARE TO LOCATED ON THE FIELD SIDE OF EACH EXTREME OUTSIDE TRACK.
 - C.- ALL SIGNS SHALL BE ERECTED 10 TO 25 FEET FROM THE GAUGE SIDE OF THE NEAREST RAIL TO THE RIGHT OF THE TRACK AS VIEWED FROM AN APPROACHING TRAIN. IN RESTRICTED SIDE CLEARANCE AREAS, THE MINIMUM DISTANCE OF 6 FEET FROM GAUGE SIDE OF THE NEAREST RAIL TO ANY PORTION OF THE SIGN MUST BE MET WITH CONSIDERATION GIVEN TO CURVED AND SUPERELEVATED FEATURES.
 - D.- ALL SIGNS SHALL BE AT A MINIMUM OF 8 FEET FROM TOP OF RAIL TO THE CENTRE LINE OF THE LOWEST SIGN ON THE POST.
 - E.- ALL SIGNS SHALL BE MOUNTED ON THE STANDARD " U " POST FOR TRACK SIGNS, UNLESS OTHERWISE SPECIFIED.
 - F.- ALL POSTS MUST PENETRATE GROUND A MINIMUM OF 4 FEET.
2. ALL SIGNS SHALL BE LOCATED AND ERECTED IN A MANNER THAT WILL AFFORD THE MOST ADVANTAGEOUS VIEW FROM AN APPROACHING TRAIN.

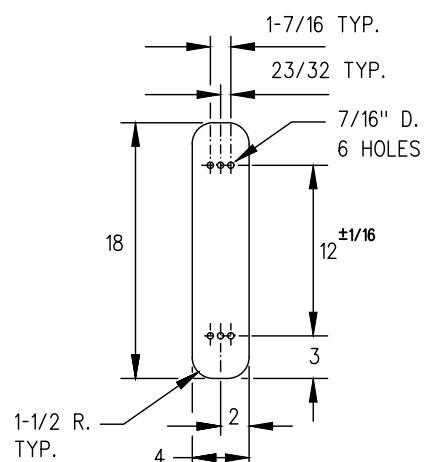

RECTANGLE (18_X_4)
WT.: 0.57 LB.

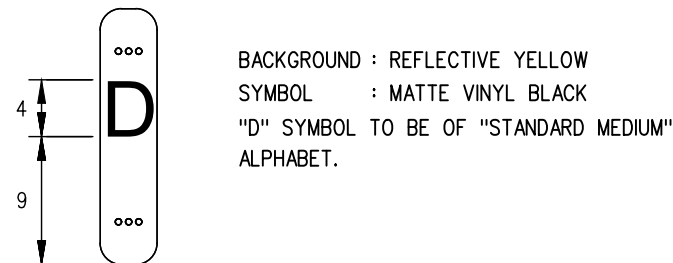

DERAIL MARKER SIGN

DERAIL MARKER SIGNS ARE TO BE LOCATED AT ALL HAND THROWN DERAILS EXCEPT WHERE THE DERAIL IS EQUIPPED WITH A TARGET STAND. SIGN TO HAVE TWO BLADES FRONT AND BACK OF POST. ERECT SIGN A DISTANCE OF 6' MINIMUM AND 9' MAXIMUM FROM GAUGE SIDE OF RAIL CONTAINING THE DERAIL. NOTE.- HANDLE OF SWITCH STAND CONTROLLING TRACK WITH A DERAIL INSTALLATION MUST BE PAINTED YELLOW. IN AREAS OF EXTREME SNOW CONDITIONS DERAIL MARKER SIGNS SHOULD BE RAISED ACCORDINGLY.

ITEM NO.	DESCRIPTION	PLAN NUMBER
1	SIGN (STATE TYPE AND STOCK NUMBER)	GTS-0720
2	" U " POST FOR TRACK SIGNS	GTS-0719
3	BLOCK FILLER FOR POST (CAST OR FORMED)	GTS-0719
4	FIBRE WASHER 3/8 I.D. x 5/8 O.D. x 1/16 THICK	—
5	3/8 DIA.-16 UNC RD. CAP SCREW 2-1/2 LG. C/W SQ. NUT	—
6	SPRING WASHER HELICAL FOR 3/8 CAP SCREW, PLATED	—
7	PLATE WASHER 7/16 I.D. x 1 O.D. x 5/64 THICK, PLATED	—

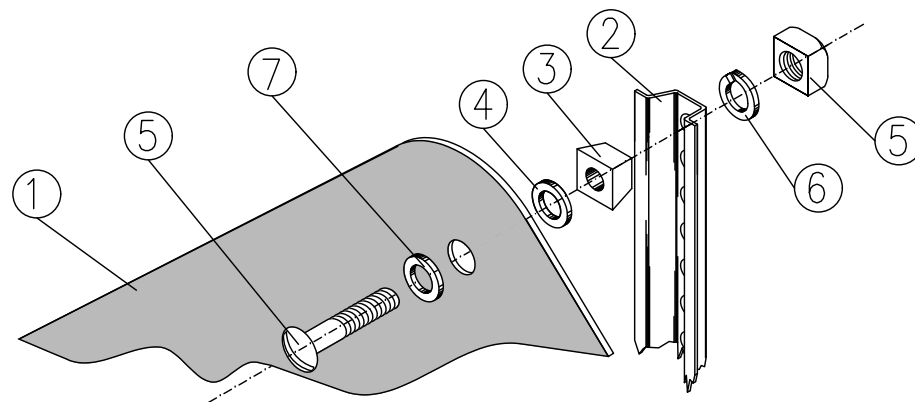

METRIC CONVERSION: 1 inch=25.4mm, 1 foot=304.8mm

No.	Date	Revision	By	Approved
1	18/07/27	ADDED IMPERIAL TO METRIC CONVERSION NOTE		

Standard/		SIGNS	
Drawn	MG	Checked	GGG
		Approved	<i>[Signature]</i> VP Engineering & Asset Management



Date	SEPT 15/2017	Plan Number	GTS-0720	Rev	1
------	--------------	-------------	----------	-----	---