

SIGN BLANKS

MANUFACTURING DETAILS

LOCATION

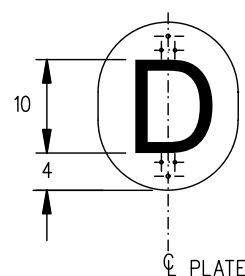
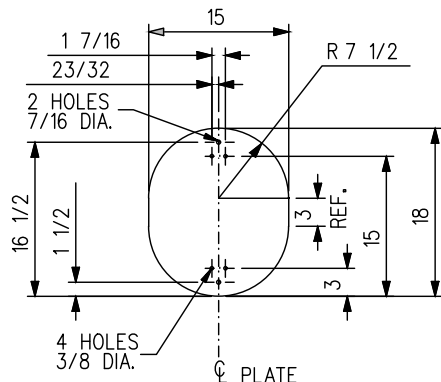

BACKGROUND: REFLECTIVE YELLOW (BOTH SIDES)
 LETTER: REFLECTIVE RED (BOTH SIDES)
 "D" SYMBOL TO BE OF "STANDARD MEDIUM" ALPHABET.

ON SUBDIVISION SIDINGS OR OTHER SIGNALLED TRACKS SPECIFIED IN SUBDIVISION FOOTNOTES OR SPECIAL INSTRUCTIONS AS HAVING EXEMPTION DERAIL PROTECTION.

EXEMPTION DERAIL SIGN

ITEM NO.	DESCRIPTION	PLAN NUMBER
1	SIGN (STATE TYPE AND STOCK NUMBER)	GTS-0720
2	3/8 DIA.-16 UNC RD. CAP SCREW 2-1/2 LG. C/W SQ. NUT	—
3	SPRING WASHER HELICAL FOR 3/8 CAP SCREW, PLATED	—
4	PLATE WASHER 7/16 I.D. x 1 O.D. x 5/64 THICK, PLATED	—

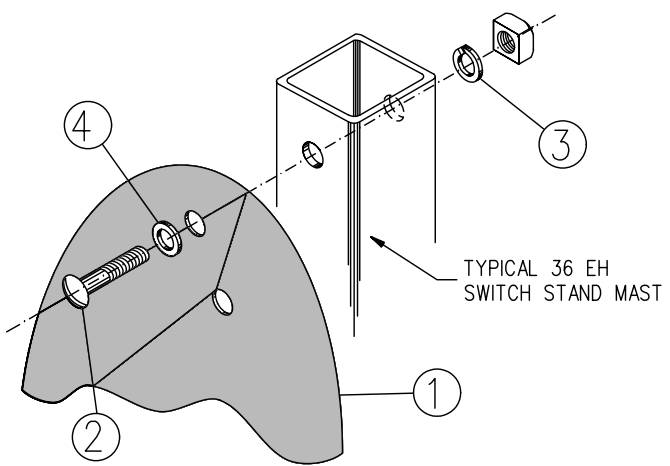

ITEM NO.	DESCRIPTION	PLAN NUMBER
1	SIGN (STATE TYPE AND STOCK NUMBER)	GTS-0720
2	5/16" DIA.U-BOLT 1-1/2 LG. C/W HEX. NUTS	GTS-1312/1
3	SPRING WASHER HELICAL FOR 5/16 U-BOLT , PLATED	—

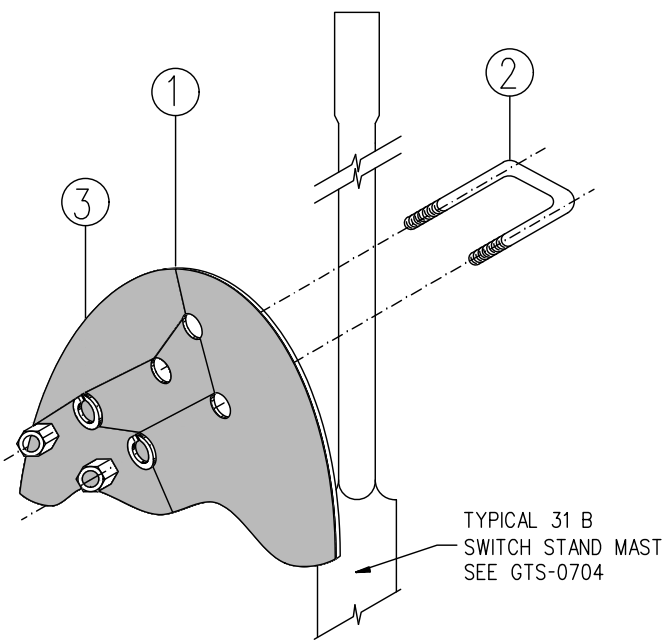

NOTES :

GENERAL :

1. WHEN REQUISITIONING SIGNS, QUANTITY, STOCK NUMBER AND CHARACTERISTICS (WHEN REQUIRED) MUST BE INDICATED ON REQUISITION. HARDWARE MUST ALSO BE ORDERED ACCORDING TO ILLUSTRATIONS SHOWING THE NUMBER OF BOLT HOLES PER SIGN.
2. FULL SIZE SIGN TEMPLATES AVAILABLE UPON REQUEST.

MATERIALS:

1. SIGN BLANKS TO BE ALUMINUM SHEET, ALLOY 3003, H14 (12 GA.) MILL FINISH.
2. REFLECTIVE SHEETING MUST CONFORM TO THE LATEST ISSUE OF CANADIAN GENERAL STANDARDS BOARD (CGSB) STANDARD 62-GP-11 M, LEVEL 1 MATERIAL.

MANUFACTURING :

1. COLOR SHEETING AND SYMBOLS ARE APPLIED ON BOTH SIDES OF SIGN BLANK.
2. ALL DIMENSIONS ARE IN INCHES.
3. ALL HOLES TO BE PUNCHED OR DRILLED.
4. ALUMINUM UNPAINTED SURFACE MUST BE THOROUGHLY DEGREASED, ETCHED, AND RINSED.
5. SHEETING TO BE APPLIED DIRECTLY TO THE PREPARED ALUMINUM SURFACE.

ERECTION :

1. ALL EXEMPTION DERAIL SIGNS ARE TO BE MOUNTED ON THE SWITCH STAND MAST SUCH THAT:
 - A.- THE REFLECTIVE TARGET IS VISIBLE WHEN IN THE DERAILING POSITION.
 - B.- ONE TARGET IS INSTALLED ON EACH SWITCH STAND MAST.
 - C.- WHEN VIEWED FROM THE CAR STORAGE SIDE OF THE DERAIL(DERAILING SIDE) THE SWITCH STAND MAST WILL BE VISIBLE OVER THE TARGET. WHEN VIEWED FROM THE OPPOSITE SIDE THE TARGET WILL NOT BE OBSTRUCTED BY THE MAST.

METRIC CONVERSION: 1 inch=25.4mm, 1 foot=304.8mm

1	18/07/27	ADDED IMPERIAL TO METRIC CONVERSION NOTE	
No.	Date	Revision	By Approved

Standard/
**SIGNS
 EXEMPTION DERAIL**

Drawn THM Checked GM Approved *[Signature]*
 VP Engineering & Asset Management



Date SEPT 15/2017 Plan Number GTS-0720 Rev 1